

SG-16N/20N Series

Low-speed Granulators

Date: Apr, 2013

Version: Ver.B (English)



Contents

1. General Description	11
1.1 Coding Principle	12
1.2 Feature	12
1.3 Technical Specifications.....	14
1.3.1 Technical Specifications (SG-16N).....	14
1.3.2 Technical Specifications (SG-20N).....	15
1.3.3 Dimensions (SG-16N/20N).....	16
1.4 Safety Regulations.....	17
1.4.1 Safety Signs and Labels	17
1.4.2 Transportation and Storage of the Machine.....	19
1.5 Exemption Clause	21
2. Structural Features and Working Principle	22
2.1 General Description	22
2.1.1 Working Principle.....	22
2.2 Safety System.....	23
2.2.1 Emergency Stop Switch.....	23
2.2.2 Safety System	24
2.2.3 Hexagon Screw	24
2.3 Assembly Drawing	25
2.3.1 Assembly Drawing (SG-1621N).....	25
2.3.2 Parts List (SG-1621N)	26
2.3.3 Assembly Drawing (SG-1628N).....	27
2.3.4 Parts List (SG-1628N)	28
2.3.5 Assembly Drawing (SG-1635N(H)).....	29
2.3.6 Parts List (SG-1635N(H))	30
2.3.7 Assembly Drawing (SG-2028N(H)).....	32
2.3.8 Parts List (SG-2028N(H))	33
2.3.9 Assembly Drawing (SG-2028NC(H))	35
2.3.10 Parts List (SG-2028NC(H)).....	36
2.3.11 Assembly Drawing (SG-2042N(H)).....	38
2.3.12 Parts List (SG-2042N(H))	39

2.3.13	Assembly Drawing (SG-2042NC(H))	41
2.3.14	Parts List (SG-2042NC(H))	42
2.3.15	Cutting Chamber	44
2.3.16	Cutting Chamber Parts List	44
2.3.17	Blade Rest	45
2.3.18	Transmission Parts	47
2.3.19	Transmission Parts Parts List	47
2.3.20	Feed Port, Feed Box and Material Check Plate	48
2.3.21	Feed Port, Feed Box and Material Check Plate Parts List	48
2.3.22	Screen and Screen Frame	49
2.3.23	Screen and Screen Frame Parts List	49
2.4	Electrical Diagram	50
2.4.1	Electrical Circuit (400V)	50
2.4.2	Main Circuit (400V)	51
2.4.3	Components Layout (400V)	54
2.4.4	Electrical Components List (400V)	55
2.4.5	Electrical Circuit (230V)	60
2.4.6	Main Circuit (230V)	61
2.4.7	Components Layout (230V)	64
2.4.8	Electrical Components List (230V)	65
2.5	Electrical Components Description	69
2.6	Optional Accessories	69
2.6.1	Screen	69
2.6.2	Blade Selection	69
2.6.3	30 Seconds Instant recycling system	70
2.6.4	Proportional Valve	74
3.	Installation and Debugging	77
3.1	Installation Notice	78
3.2	Installation Place	79
3.3	Installation of Bearing and Blade Rest	79
3.4	Installation of Rotating Blade and fixed Blade	81
3.5	Installation of Belt and Belt Pulley	82
3.6	Installation of Feed Box and Feed Port	85
3.7	Installation of Screen and Screen Frame	86

3.8	Installation of Material Collection Box	88
4.	Operation Guide	90
4.1	Startup Pretest	90
4.1.1	Before the First Startup.....	90
4.1.2	After First Startup for 2 Hours.....	90
4.1.3	After First Startup for 20~30 Hours.....	91
4.2	Circuit Connection.....	91
4.3	Open the Feed Box and Storage Box	91
4.3.1	Open the Feed Box.....	91
4.3.2	Open the Storage Box	92
4.3.3	Open the Screen and Screen Frame	92
4.4	Shut Up the Feed Box and Storage Box	93
4.4.1	Close the Feed Box	93
4.4.2	Shut up the Storage Box.....	93
4.5	Start and Stop the Granulator	94
4.6	Blades Installation Adjusting (SG-20N).....	95
5.	Trouble-shooting	96
5.1	Granulator Can Not Work.....	96
5.2	Stop Due to Other Reasons	96
6.	Maintenance and Repair	98
6.1	Repair	98
6.1.1	Blades Structure in Cutting Chamber	99
6.1.2	Replace the Blades.....	99
6.2	Transmission.....	101
6.2.1	Daily Maintenance of V Belts.....	101
6.2.2	Adjustments of V Belts.....	102
6.3	Maintenance	102
6.3.1	Daily check	103
6.3.2	Weekly Check.....	103
6.3.3	Monthly Check.....	103
6.4	Cleaning.....	104
6.5	Maintenance Schedule.....	105
6.5.1	About the Machine.....	105

6.5.2	Check After Installation.....	105
6.5.3	Daily Check	105
6.5.4	Weekly Check.....	105
6.5.5	Monthly Check.....	106
6.5.6	Check Half-yearly or Every 1000 Running Hours	106
6.5.7	3 year Checking.....	106

Table index

Table 1-1:	Technical Specifications (SG-16N).....	14
Table 1-2:	Technical Specifications (SG-20N).....	15
Table 2-1:	Parts List (SG-1621N)	26
Table 2-2:	Parts List (SG-1628N)	28
Table 2-3:	Parts List (SG-1635N)	30
Table 2-4:	Parts List (SG-1635NH).....	31
Table 2-5:	Parts List (SG-2028N)	33
Table 2-6:	Parts List (SG-2028NH).....	34
Table 2-7:	Parts List (SG-2028NC).....	36
Table 2-8:	Parts List (SG-2028NCH)	37
Table 2-9:	Parts List (SG-2042N)	39
Table 2-10:	Parts List (SG-2042NH).....	40
Table 2-11:	Parts List (SG-2042NC).....	42
Table 2-12:	Parts List (SG-2042NCH)	43
Table 2-13:	Cutting Chamber Parts List.....	44
Table 2-14:	Staggered Blade Rest Parts List.....	45
Table 2-15:	Paddle Blade Rest Parts List	46
Table 2-15:	Transmission Parts Parts List	47
Table 2-16:	Feed Port, Feed Box and Material Check Plate Parts List.....	48
Table 2-17:	Screen and Screen Frame Parts List.....	49
Table 2-18:	Electrical Circuit (400V).....	50
Table 2-19:	Electrical Components List of SG-1621N (400V).....	55
Table 2-20:	Electrical Components List of SG-1628N/1635N/2028N (400V)....	57
Table 2-21:	Electrical Components List of SG-1635NH/2028NH/2042N (400V)	58

Table 2-22: Electrical Components List of SG-2042NH (400V)	59
Table 2-23: Electrical Circuit (230V).....	60
Table 2-24: Electrical Components List of SG-1621N (230V).....	65
Table 2-25: Electrical Components List of SG-1628N/1635N/2028N (230V)....	66
Table 2-26: Electrical Components List of SG-1635NH/2028NH/2042N (230V)	67
Table 2-27: Electrical Components List of SG-2042NH (230V).....	68

Picture index

Picture 1-1: Dimensions (SG-16N/20N).....	16
Picture 2-1: Working Principle	22
Picture 2-2: Safety System	23
Picture 2-3: Emergency Stop Switch	23
Picture 2-4: Safety System	24
Picture 2-5: Assembly Drawing (SG-1621N)	25
Picture 2-6: Assembly Drawing (SG-1628N)	27
Picture 2-7: Assembly Drawing (SG-1635N(H))	29
Picture 2-8: Assembly Drawing (SG-2028N(H))	32
Picture 2-9: Assembly Drawing (SG-2028NC(H)).....	35
Picture 2-10: Assembly Drawing (SG-2042N(H))	38
Picture 2-11: Assembly Drawing (SG-2042NC(H)).....	41
Picture 2-12: Cutting Chamber	44
Picture 2-13: Staggered Blade Rest	45
Picture 2-14: Paddle Blade Rest	46
Picture 2-14: Transmission Parts.....	47
Picture 2-15: Feed Port, Feed Box and Material Check Plate	48
Picture 2-16: Screen and Screen Frame	49
Picture 2-17: Main Circuit 1(400V).....	51
Picture 2-18: Main Circuit 2(400V).....	52
Picture 2-19: Main Circuit 3(400V).....	53
Picture 2-20: Components Layout (400V).....	54
Picture 2-21: Main Circuit 1(230V).....	61
Picture 2-22: Main Circuit 2(230V).....	62

Picture 2-23: Main Circuit 3(230V).....	63
Picture 2-24: Components Layout (230V).....	64
Picture 2-25: Electrical Components Description.....	69
Picture 2-26: Screen.....	69
Picture 2-27: SKD-11.....	70
Picture 2-28: 30 Seconds Instant recycling system.....	70
Picture 2-29: 30 Seconds Instant Recycling System 1.....	70
Picture 2-30: 30 Seconds Instant Recycling System 2.....	71
Picture 2-31: 30 Seconds Instant Recycling System 3.....	71
Picture 2-32: 30 Seconds Instant Recycling System 4.....	72
Picture 2-33: 30 Seconds Instant Recycling System 5.....	72
Picture 2-34: 30 Seconds Instant Recycling System 6.....	72
Picture 2-35: Loading With High Pressure Air.....	73
Picture 2-36: Loading With Blower.....	73
Picture 2-37: Option 3: Blower + Cyclonic Loading Device.....	73
Picture 2-38: Control Box.....	74
Picture 2-39: Valve Body.....	74
Picture 2-40: Dust separating System.....	75
Picture 3-1: Installation Space.....	78
Picture 3-2: Installation Place.....	79
Picture 3-3: Installation of Bearing and Blade Rest 1.....	79
Picture 3-4: Installation of Bearing and Blade Rest 2.....	80
Picture 3-5: Installation of Bearing and Blade Rest 3.....	80
Picture 3-6: Installation of Bearing and Blade Rest 4.....	80
Picture 3-7: Installation of Rotating Blade and fixed Blade 1.....	81
Picture 3-8: Installation of Rotating Blade and fixed Blade 2.....	81
Picture 3-9: Installation of Rotating Blade and fixed Blade 3.....	81
Picture 3-10: Installation of Rotating Blade and fixed Blade 4.....	82
Picture 3-11: Installation of Belt and Belt Pulley 1.....	82
Picture 3-12: Installation of Belt and Belt Pulley 2.....	82
Picture 3-13: Installation of Belt and Belt Pulley 3.....	83
Picture 3-14: Installation of Belt and Belt Pulley 4.....	83
Picture 3-15: Installation of Belt and Belt Pulley 5.....	83
Picture 3-16: Installation of Belt and Belt Pulley 6.....	84

Picture 3-17: Installation of Belt and Belt Pulley 7	84
Picture 3-18: Installation of Belt and Belt Pulley 8	84
Picture 3-19: Installation of Belt and Belt Pulley 9	85
Picture 3-20: Installation of Feed Box and Feed Port 1	85
Picture 3-21: Installation of Feed Box and Feed Port 2	85
Picture 3-22: Installation of Screen and Screen Frame 1	86
Picture 3-23: Installation of Screen Frame 1	86
Picture 4-1: Open the Feed Box	92
Picture 4-2: Open the Storage Box	92
Picture 4-3: Open the Screen and Screen Frame 1	92
Picture 4-4: Open the Screen and Screen Frame 2	93
Picture 4-5: Close the feed box	93
Picture 4-6: Shut up the Screen and Screen Frame	94
Picture 4-7: Main Power Switch	94
Picture 4-8: Stop, Emergency Stop and Startup button	95
Picture 4-9: Blades Installation Adjusting (SG-20N)	95
Picture 6-1: Blades Structure in Cutting Chamber	99
Picture 6-2: Rotate Blades Sharpening	99
Picture 6-3: Maintain and Clean Blades	100
Picture 6-4: Transmission	102
Picture 6-5: Adjustments of V Belts 1	102
Picture 6-6: Adjustments of V Belts 2	102
Picture 6-7: Star Screw	103
Picture 6-8: Clearing the Dust Collection Chambers	104

1. General Description



Please read this manual carefully before using this machine in order to operate correctly against any damage caused due to improper operation.



Note!

Always take great care when the knives are within reach, they are very sharp and can cause personal injury.



Forbidden to process flammable or toxic material!

SG-16N/20N series low-speed granulators are suitable for crushing sprues material and a few rejects. It is set on the side of Plastics Molding Machines and Picker, collocating with belt conveyor. It features low speed, big driving torque, low noise, little dust level and simple operation.



Model: SG-1635N

1.1 Coding Principle

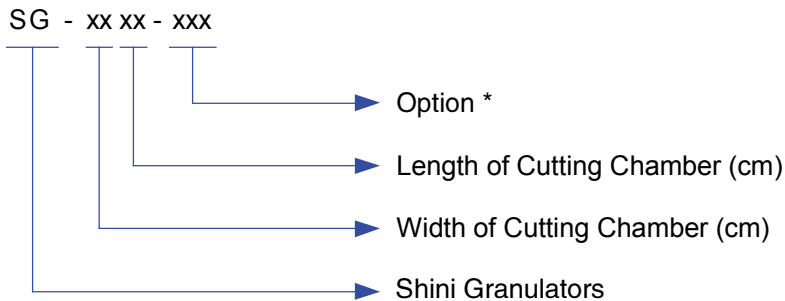

Note: *

BR=Loading by Bolwer S=Smaller Motor Power F=Fiber-added

H=Higher Motor Power VR=Loading by High Pressure Air CE=CE Conformity

1.2 Feature

Standard configuration

- 1) SG-16N/SG-20NC series adopt new type staggered blades and unfixed blades which can keep a settled cutting clearance without adjustment after resharpen; SG-20N employs paddle blades and integration design to obtain better cutting performance.
- 2) Low granulating speed and sharp angle design of rotating blades are helpful for smooth and continuous operation.
- 3) SG-20N series is equipped with presetting knife jig, simple cutter installation adjusting technology makes the rotating blades be adjusted within clamps outside machine, no longer needs to be adjusted from inside of machine as before.
- 4) The material collector is located outside the cutting chamber to avoid leakage.
- 5) Optimal cutting angle makes resistance small and avoid blockage to improve cutting efficiency.
- 6) Optimal design can effectively reduce vibration during operation of granulator.
- 7) Low speed granulating ensures well-proportioned granules and low dust level.
- 8) Low speed and sound-proof material hopper brings a quieter operation environment.

- 9) Easy access for easy maintenance and cleaning.
- 10) Small in size with castors for easy moving.
- 11) High safety grade design to comply with European safety standard.
- 12) With built-in magnet installed at the inlet of the feeding chamber, metal impurities in the materials can be avoided.

Accessory option

- 1) 30-sec instant recycling system, regrind conveying via blower & cyclone, dust separator, height-increasing storage tank and full-receiver alarm device. Straight hoppers, special screens and double-layer screens.
- 2) Straight hoppers, double-layer screen, special screens.
- 3) For granulating fibre-added material, it increases fibre-added granulator model for choose. Adopt surface-hardening treatment on the material contacting components. SG-20N fibre-added model chooses V-4E blade material.
- 4) Coiled spring conveyor can make it more convenient for users to collect the regrinds from the discharge port automatically by putting a container under the discharge port without detaching the collecting box from the granulator.

All service work should be carried out by a person with technical training or corresponding professional experience. The manual contains instructions for both handling and servicing. Chapter 6, which contains service instructions intended for service engineers. Other chapters contain instructions for the daily operator.

Any modifications of the machine must be approved by SHINI in order to avoid personal injury and damage to machine. We shall not be liable for any damage caused by unauthorized change of the machine.

Our company provides excellent after-sales service. Should you have any problem during using the machine, please contact the company or the local vendor.

Headquarter and Taipei factory: Shini Plastics Technologies (Dongguan), Inc:
Tel: (886) 2 2680 9119 Tel: (86) 769 8111 6600

Shini Plastics Technologies India Pvt.Ltd.:
Tel: (91) 250 3021 166

1.3 Technical Specifications

1.3.1 Technical Specifications (SG-16N)

Table 1-1: Technical Specifications (SG-16N)

Model	SG-1621N	SG-1628N	SG-1635N(H)
Motor Power (kW, 50/60Hz)	1.5	2.2	2.2 (3.0)
Rotating Speed (rpm, 50/60Hz)	230	235	235 (240)
Material of Blades	SKD11 (D2)	SKD11 (D2)	SKD11 (D2)
Type of Blades	Staggered	Staggered	Staggered
Number of Fixed Blades	2×1	2×1	2×2
Number of Rotating Blades	9	12	15
Presetting Knife Jig	-	-	-
Cutting Chamber (mm)	160×210	160×280	160×350
Max. Throughput Capacity (kg/hr)	35	50	60 (80)
Noise Level dB(A)	85~90	85~90	85~90
Dia. of Screen Mesh (mm)	√(Φ5)	√(Φ5)	√(Φ5)
30-sec. Instant Recycler	○	○	○
Regrind Conveyor (BC Type)	○	○	○
Dust Separator (with Instant Recycling)	○	○	○
Level Detector	○	○	○
Straight Feed Hopper	-	-	-
Proportional Valve	○	○	○
Special Screens (mm)	○	○	○
Height-increasing Storage Bin	○	○	○
Double-layer Screen	○	○	○
Coiled spring conveyor (EA)	○	○	○
Dimensions			
H (mm)	1200	1200	1200
H1(mm)	1400	1400	1400
H2(mm)	550	550	550
W (mm)	505	575	645
W1 (mm)	330	400	470
D (mm)	630	630	630
D1 (mm)	385	385	385
Weight (kg)	175	195	210/225

Note: 1) "√" standard, "○" optional.

2) "H" Refers to higher motor power.

3) For stainless steel made feed port and manual storage bin, plus "R" at model behind.

4) Max. capacity of the machine is subject to diameter of screen hole and composition of the material.
Continually with PET preforms.

5) Noise level will vary with different materials and motor types.

6) For avoiding plastic to adhibit the blade, all materials should be crushed at normal temperature.

7) Power supply: 3Φ, 230 / 400 / 460 / 575VAC, 50 / 60Hz.

1.3.2 Technical Specifications (SG-20N)

Table 1-2: Technical Specifications (SG-20N)

Model	SG-2028N(H)	SG-2028NC(H)	SG-2042N(H)	SG-2042NC(H)
Motor Power (kW, 50/60Hz)	2.2 (3.0)	2.2(3.0)	3.0 (4.0)	3.0(4.0)
Rotating Speed (rpm)	290	290	290	290
Material of Blades	SKD11 (D2)	SKD11 (D2)	SKD11 (D2)	SKD11 (D2)
Type of Blades	片刀	爪刀	片刀	爪刀
Number of Fixed Blades	2	2	2	2
Number of Rotating Blades	3	12	3	18
Cutting Chamber	✓	-	✓	-
Presetting Knife Jig(mm)	200×280	200×280	200×420	200×420
Max. Throughput Capacity (kg/hr)	80	80	135	135
Noise Level dB(A)	85~90	85~90	85~90	85~90
Dia. of Screen Mesh (mm)	✓(Φ6)	✓(Φ6)	✓(Φ6)	✓(Φ6)
30-sec. Instant Recycler	○	○	○	○
Regrind Conveyor (BC Type)	○	○	○	○
Dust Separator (with Instant Recycling)	○	○	○	○
Level Detector	○	○	○	○
Straight Feed Hopper	○	○	○	○
Proportional Valve	○	○	○	○
Special Screens (mm)	○	○	○	○
Height-increasing Storage Bin	○	○	○	○
Double-layer Screen	○	○	○	○
Coiled spring conveyor (EA)	○	○	○	○
Dimensions				
H (mm)	1270	1270	1270	1270
H1 (mm)	1450	1450	1450	1450
H2 (mm)	550	550	550	550
W (mm)	575	575	715	715
W1 (mm)	405	405	545	545
D (mm)	695	695	695	695
D1 (mm)	435	435	435	435
Weight (kg)	265/280	280/295	300/315	320/335

Note: 1) "✓" stands for standard, "○" stands for options.

2) "H" stands for higher motor power. "C" stands for staggered blades.

3) For stainless steel made feed port and height-increasing storage bin, add "R" at the end of the code.

4) Max. capacity of the machine is subject to diameter of screen hole and composition of the material. The listed maximum output is tested continually with PET preforms.

5) Noise level will vary with different materials and motor types.

6) For avoiding plastic to adhibit the blade, all materials should be crushed at normal temperature.

7) Power supply: 3Φ, 400 / 460 / 575VAC, 50 / 60Hz.

1.3.3 Dimensions (SG-16N/20N)

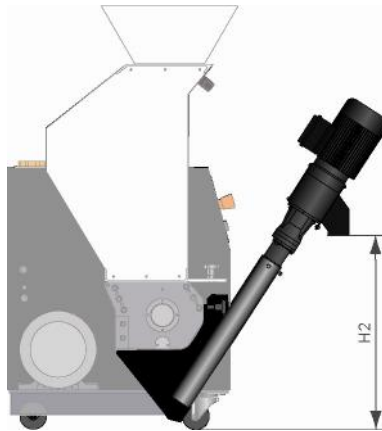
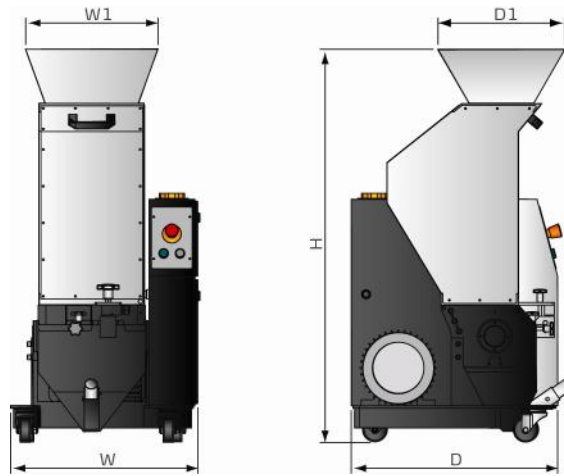

Optionally Equipped with Coiled Spring Conveyor

Picture 1-1: Dimensions (SG-16N/20N)

1.4 Safety Regulations

Follow the instructions in this manual to avoid personal injury and damage to machine components.

1.4.1 Safety Signs and Labels



Electrical installation must only be done by a competent electrician!



Before the granulator is opened for servicing and maintenance, always disconnect the power with both the main switch and the control switch on the granulator.



Never put any part of your body through the granulator openings, unless both the main switch and the control switch on the granulator are in "Off" position.



High voltage! Danger!

This sign is attached on the control box and the wiring box.



Be careful with the rotating knives, they are very sharp and can cause personal injury!



Be careful with the rotating knives, they are very sharp and can cause personal injury!



The granulator should not be able to start before the feed box and screen frame are properly closed.



Attention please!

Ear protection is used during granulating of plastic materials.



Attention!

No need for regular inspection because all the electrical parts in the control unit are fixed tightly!



Make sure the power has been cut off before opening the feed box.



Loading blower is applicable to convey regrind and powder, and it requires that the temperature of regrind and powder should not be more than 80°C.



The loading blower has great suction power and it is easy to get things or clothes sucked into, so it should have a protective cover.







Air inlet dust clean.



Concerning SG-20N the cutting chamber should be heat-processed and the blades must be changed before the granulators deal with fibre added material.

When operate the granulator, please notice the following signs

	Hazard High voltage! May lead to casualty or other serious danger. Please cut off the power before repairing. Circuit diagram should only be changed by professionals. Grounding is necessary.
	Warning Pinch risk when moving belt. Take out or open protective cover is not allowed when it is running.
	Warning There is a pinch risk for this protective cover keep some distance away from that.

	 <p>Warning</p> <p>The cutter are very sharp, can cause injury take out or open protective cover is not allowed when it is running. Keep some distance away from the cutters.</p>
	 <p>Notice</p> <p>Read the instruction manual carefully before operating. Before start, do the safety device test according to the instruction. It is not allowed to change the design of the machine unless it is approved from the manufacturer.</p>

1.4.2 Transportation and Storage of the Machine

Transportation

- 1) SG-16N / 20N series of granulators are packed in plywood cases with wooden pallet at the bottom, suitable for quick positioning by fork lift.
- 2) After unpacked, castors located at the bottom of the machine can be used for easier movement.
- 3) Do not rotate the machine and avoid collision with other objects during transportation to prevent improper functioning.
- 4) The structure of the machine is well-balanced and has device for transportation although it should also be handled with care when lifting the machine for fear of falling down.
- 5) The machine and its attached parts can be kept at a temperature from -25°C to $+55^{\circ}\text{C}$ for long distance transportation and for a short distance, it can be transported with temperature under $+70^{\circ}\text{C}$.

Storage

- 1) SG-16N / 20N series granulators should be stored indoors with temperature kept from 5°C to 40°C and humidity below 80%.
- 2) Disconnect all power supply and turn off main switch and control switch.
- 3) Keep the whole machine, especially the electrical components away from water to avoid potential troubles caused by the water.
- 4) Plastic film should be used to protect the machine from dust and rains.

Working Environment

The machine should be operated: Indoors in a dry environment with max. temperature +45°C and humidity no more than 80%.

Do not use the machine:



- 1) If it is with a damaged cord.
- 2) On a wet floor or when it is exposed to rain to avoid electrical shock.
- 3) If it has been dropped or damaged until it is checked or fixed by a qualified serviceman.
- 4) This equipment works normally in the environment with altitude within 3000m.
- 5) At least a clearance of 1m surrounding the equipment is required during operation. Keep this equipment away from flammable sources at least two meters.
- 6) Avoid vibration, magnetic disturbance at the operation area.

Rejected Parts Disposal

When the equipment has run out its life time and can not be used any more, unplug the power supply and dispose of it properly according to local code.



Fire hazard

In case of fire, Co₂ dry powder fire extinguisher should be applied.



Flammable materials or materials which are contaminated by flammable substances/liquid may not be processed in the granulator. Serious risk of fire or explosion.



It is very important to tighten the screw as required torque.



When process item is longer than hopper through, please cut long items into half until the length is shorter before processing.



Please don't put materials into the granulator if they are thinner than 2mm and are soft and flexible, like rubber.

1.5 Exemption Clause

The following statements clarify the responsibilities and regulations born by any buyer or user who purchases products and accessories from Shini (including employees and agents).

Shini is exempted from liability for any costs, fees, claims and losses caused by reasons below:

1. Any careless or man-made installations, operation and maintenances upon machines without referring to the Manual prior to machine using.
2. Any incidents beyond human reasonable controls, which include man-made vicious or deliberate damages or abnormal power, and machine faults caused by irresistible natural disasters including fire, flood, storm and earthquake.
3. Any operational actions that are not authorized by Shini upon machine, including adding or replacing accessories, dismantling, delivering or repairing.
4. Employing consumables or oil media that are not appointed by Shini.

2. Structural Features and Working Principle

2.1 General Description

Granulators of SG-16N / 20N series are designed for grinding different types of plastic waste. The granulator is controlled by main power switch, emergency stop button, safety switch, start and stop button.

2.1.1 Working Principle

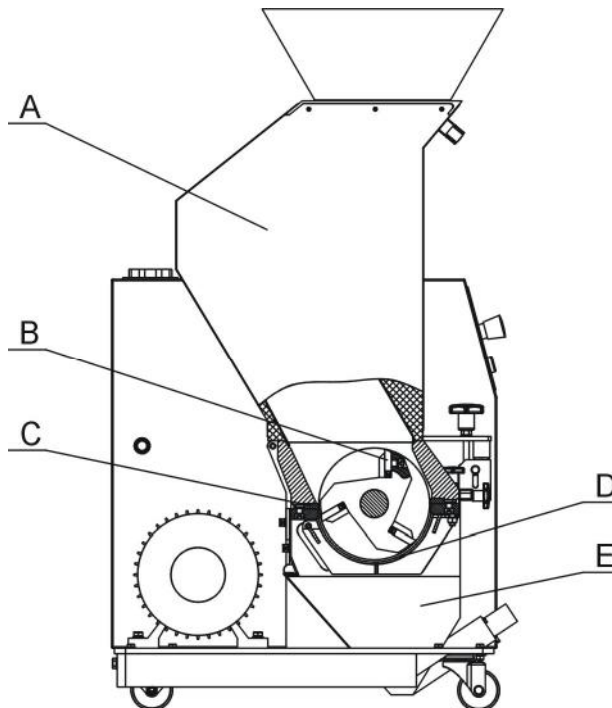

Parts name:

A. Feed box B. Rotating blade C. Fixed blade D. Screen E. Storage box

Picture 2-1: Working Principle

The material is fed in via feed box (A) and falls down to the rotating blades (B) there it grind the material against the fixed blades (C) in the cutting chamber. Underneath there is a screen (D) which the granulate passes through before it is gathered in the storage box (E). The storage box, screen and screen frame are removable. The feed box can also be opened up for easy cleaning and maintenance.

2.2 Safety System

To avoid accidental bodily injury during granulator running, a set of safety system has been designed. In any cases, the safety system cannot be changed at random. Otherwise the machine will be under dangerous condition and subject to accident happening. The maintenance and preservation of safety system shall be done by professional staff. In case the safety system of granulator is changed, our company will not perform our commitment. The replacement of all spare parts will be done by SHINI Company.



Picture 2-2: Safety System

2.2.1 Emergency Stop Switch

There is one red button on the control panel. Upon pushing it, the machine will stop running. Turn the button in the arrow direction as shown on the button, the button will reset (counter-clockwise).



Emergency stop button

Picture 2-3: Emergency Stop Switch

2.2.2 Safety System

On the granulator is equipped the safety position switch for the breaker. In case the position of storage box or feed box is changed or the breaker is loosened, it will cut off the power supply.

There is one safety switch on the granulator locating between the feed box and the storage box.



Picture 2-4: Safety System

2.2.3 Hexagon Screw

When opening the feed box and granulator chamber, a long hexagon screw should be loosened (it's just the door lock). It will take a long time to loosen the screw. And this period of time is enough for stopping the blade bearing completely to avoid personnel injury.

Prior to machine switch-on, please notice:

- 1) Check if the feed box has been locked up.
- 2) Shut the screen frame and lock the star screw tightly.

2.3 Assembly Drawing

2.3.1 Assembly Drawing (SG-1621N)

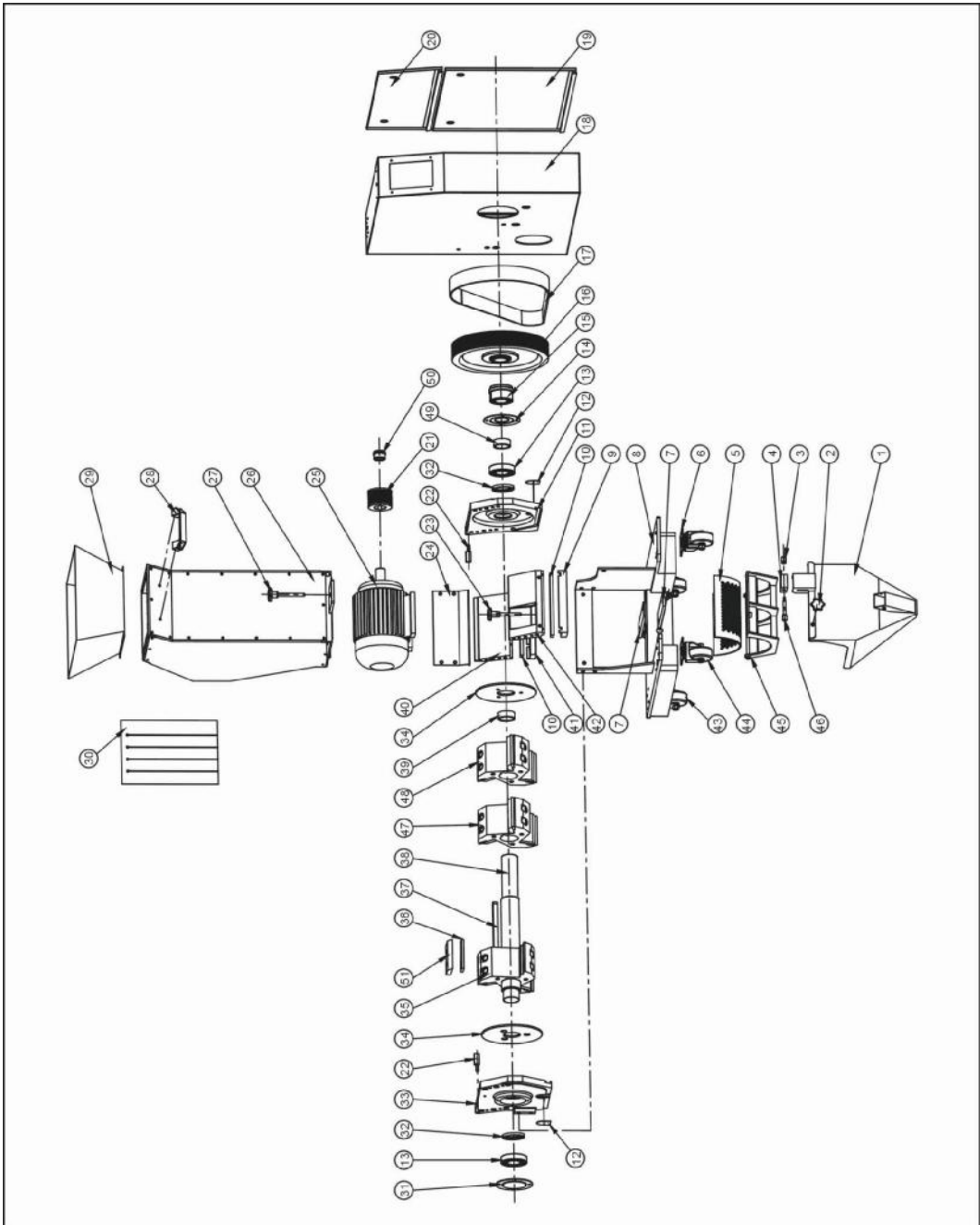

Note: Please refer to 2.3.2 material list about the parts code.

Picture 2-5: Assembly Drawing (SG-1621N)

2.3.2 Parts List (SG-1621N)

Table 2-1: Parts List (SG-1621N)

No.	Name	Part No.	No.	Name	Part No.
1	Storage box	-	24	Check plate for storage box	-
2	Knob	YR40083500000	25	Motor (1.5kW)	YM10710600300
3	Safety switch knob	BH10024200010	26	Feeding box	-
4	Safety switch installation board	BH10424500010	27	Star assembly of feeding box	BH55162800010
5	Screen (Φ4)**	BL50162111620	28	Handle*	BW20012000140
	Screen (Φ5)**	BL50162150020	29	Feeding mouth	-
	Screen (Φ6)**	BL50162111720	30	Material fender	-
	Screen (Φ7)**	BL50162103820	31	Left bearing cover plate	-
	Screen (Φ10)**	BL50162131920	32	Oil seal	YR80554200000
	Screen (Φ12)**	BL50162131020	33	Left bearing plate	BH10162010010
6	Castor	YW03000300000	34	Material fender(65Mn)	YW45162850000
7	Motor adjusting plate	-	35	Blade rest(1)	BH11162850010
8	Base	-	36	Rotating balde**	YW42162840000
9	Front pressure block	BH10162150010	37	Flat key 10X199	BH10162110010
10	Sustain brace**	YW42162100000	38	Shaft	BH55162100010
11	Right end plate	BH10161600010	39	Sleeve	BH10161500010
12	Bearing cover	-	40	Back block	BH10162600010
13	Bearing 6207DD*	YW11620700000	41	Pressure block of back block	BH10162500010
14	Right bearing cover plate	-	42	Front block	BH10162130010
15	Taper sleeve 3020-35	YW30203500000	43	Fixed castor 3"	YW03000300300
16	Large belt wheel	YW30231900000	44	Movable castor 3"	YW03000300200
17	Poly V-belt 20PJ50 *	YW30205000000	45	Screen rest	-
18	Outer shell	-	46	Safety switch installation shaft	BH10204300010
19	Outer cover board of shell	-	47	Blade rest 1	BH10116100010
20	Upper cover board of shell	-	48	Blade rest (2)	BH11162110010
21	Small belt pulley	YW30207800000	49	Sleeve 1	BH10162823010
22	Rotating shaft	BH10204100010	50	Taper sleeve 1210-28	YW30121002800
23	Star assembly of screen	BH55162820010	51	Press block for rotating blade	BH11162700010

* means possible broken parts.

** means easy broken part. and spare backup is suggested.

Please confirm the version of manual before placing the purchase order to guarantee that the item number of the spare part is in accordance with the real object.

2.3.3 Assembly Drawing (SG-1628N)

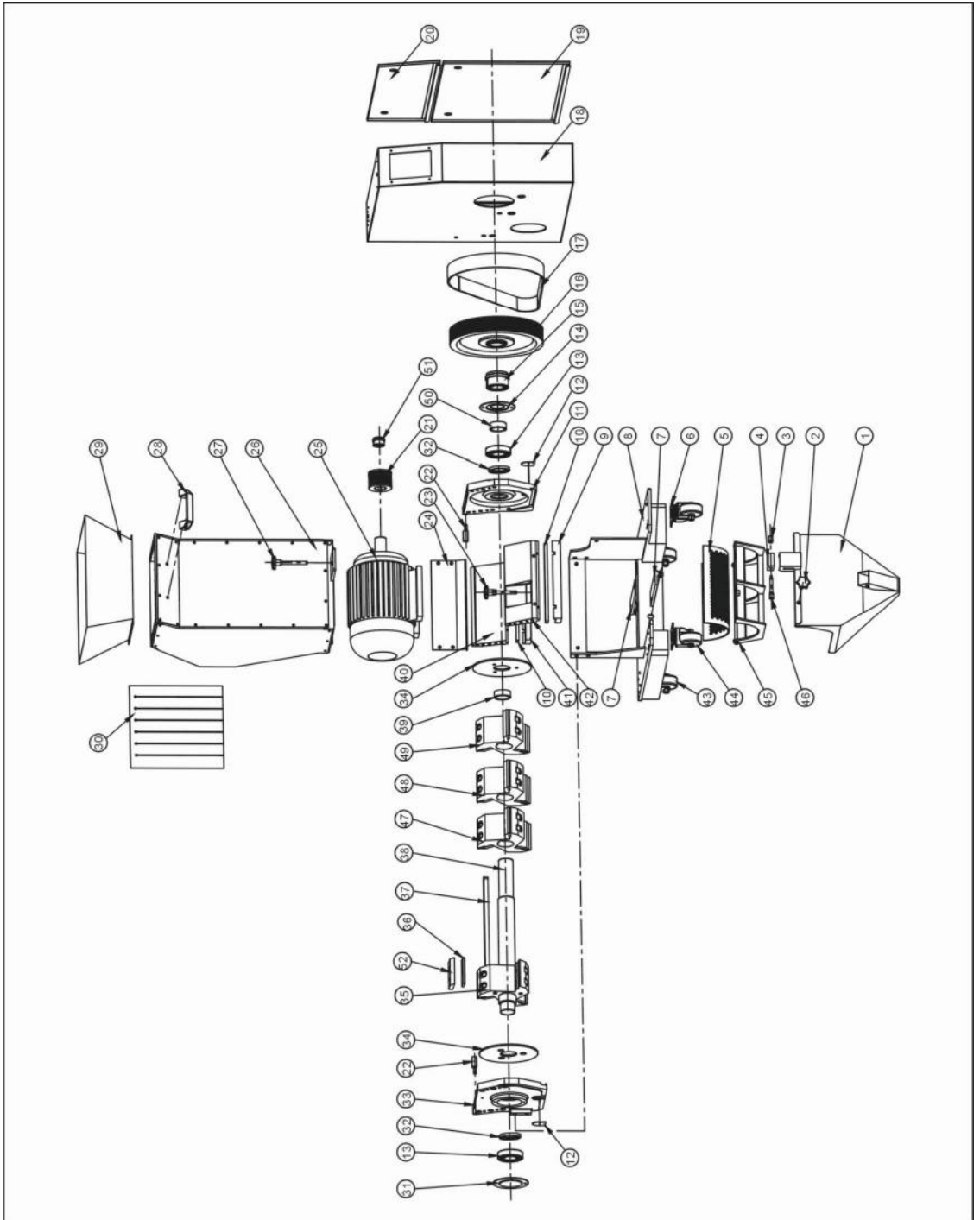

Note: Please refer to 2.3.4 material list about the parts code.

Picture 2-6: Assembly Drawing (SG-1628N)

2.3.4 Parts List (SG-1628N)

Table 2-2: Parts List (SG-1628N)

No.	Name	Part No.	No.	Name	Part No.
1	Storage box	-	25	Motor (2.2kW)	YM10692900000
2	Knob	YR40083500000	26	Feeding box	-
3	Safety switch knob	BH10024200010	27	Star assembly of feeding box	BH55162800010
4	Safety switch installation board	BH10424500010	28	Handle*	BW20012000140
5	Screen (Φ4)**	BL50162821820	29	Feeding mouth	-
	Screen (Φ5)**	BL50162860020	30	Material fender	-
	Screen (Φ6)**	BL50162821920	31	Left bearing cover plate	-
	Screen (Φ8)**	BL50162821020	32	Oil seal	YR80554200000
	Screen (Φ10)**	BL50162821120	33	Left bearing plate	BH10162010010
	Screen (Φ12)**	BL50162821220	34	Material fender (65Mn)	YW45162850000
6	Castor	YW03000300000	35	Blade rest (1)	BH11162850010
7	Motor adjusting plate	-	36	Rotating balde**	YW42162840000
8	Base	-	37	Flat key 10X268	BH10162810010
9	Front pressure block	BH10160800010	38	Shaft	BH55162600010
10	Sustain brace**	YW41162820000	39	Sleeve	BH10161500010
11	Right end plate	BH10161600010	40	Back block	BH10162900010
12	Bearing cover	-	41	Pressure block of back block	BH10160280010
13	Bearing 6207DD*	YW11620700000	42	Front block	BW30162083010
14	Right bearing cover plate	-	43	Fixed castor 3"	YW03000300300
15	Taper sleeve 3020-35	YW30203500000	44	Movable castor 3"	YW03000300200
16	Large belt wheel	YW30231900000	45	Screen rest	-
17	Poly V-belt 20PJ50 *	YW30205000000	46	Safety switch installation shaft	BH10204300010
18	Outer shell	-	47	Blade rest 1	BH10116100010
19	Outer cover board of shell	-	48	Blade rest 2	BH10216200010
20	Upper cover board of shell	-	49	Blade rest (2)	BH11162810010
21	Small belt pulley	YW30207800000	50	Sleeve 1	BH10162823010
22	Ratating shaft	BH10204100010	51	Taper sleeve 1210-28	YW30121002800
23	Star assembly of screen	BH55162820010	52	Press block for rotating blade	BH11162700010
24	Check plate for storage box	-			

* means possible broken parts. ** means easy broken part. and spare backup is suggested. Please confirm the version of manual before placing the purchase order to guarantee that the item number of the spare part is in accordance with the real object.

2.3.5 Assembly Drawing (SG-1635N(H))

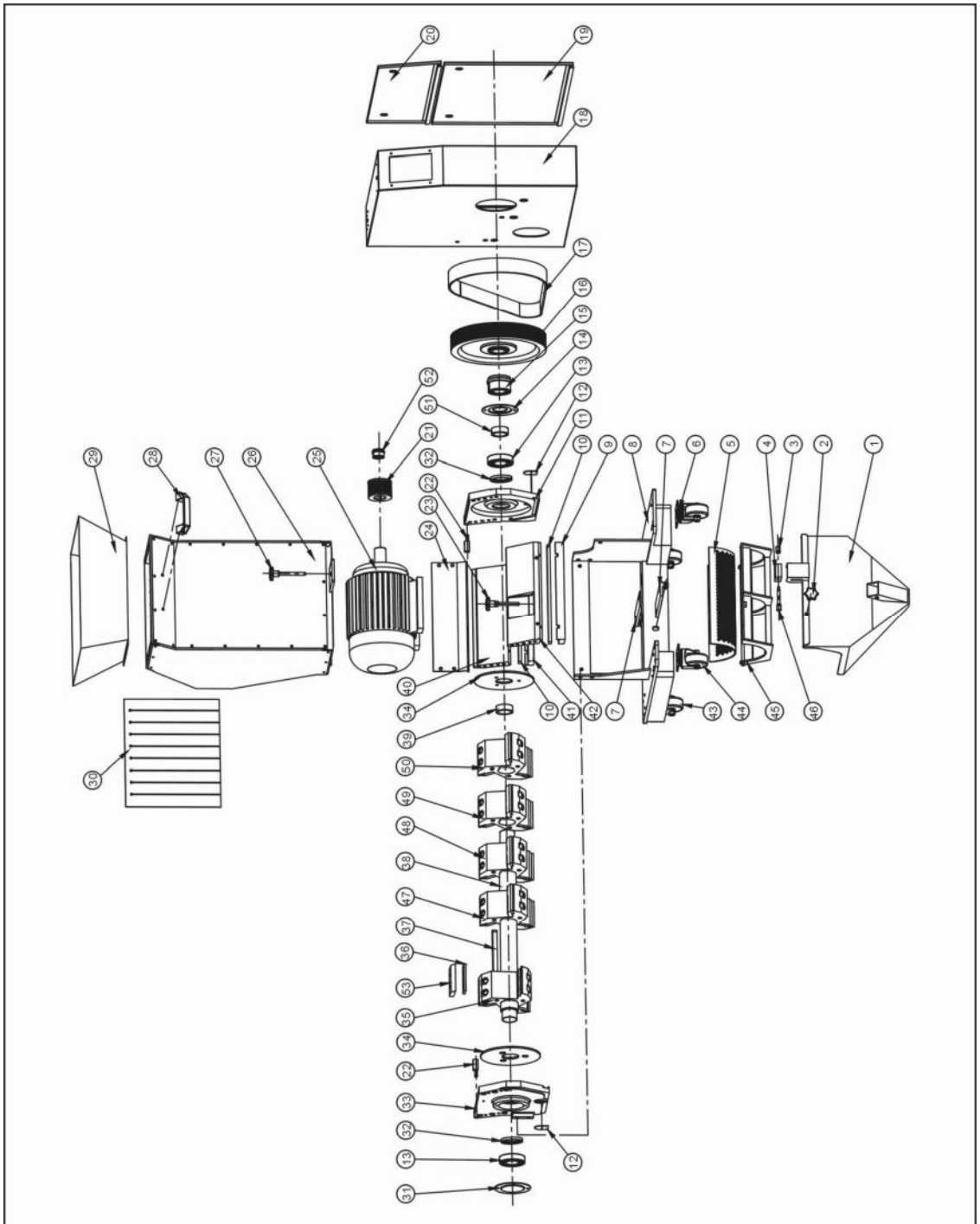

Note: Please refer to 2.3.6 material list about the parts code.

Picture 2-7: Assembly Drawing (SG-1635N(H))

2.3.6 Parts List (SG-1635N(H))

Table 2-3: Parts List (SG-1635N)

No.	Name	Part No.	No.	Name	Part No.
1	Storage box	-	25	Motor (2.2kW)	YM10692900000
2	Knob	YR40083500000	26	Feeding box	-
3	Safety switch knob	BH10024200010	27	Star assembly of feeding box	BH55162800010
4	Safety switch installation board	BH10424500010	28	Handle*	BW20012000140
5	Screen (Φ4)**	BL50163521620	29	Feeding mouth	-
	Screen (Φ5)**	BL50162050020	30	Material fender	-
	Screen (Φ6)**	BL50163521720	31	Left bearing cover plate	-
	Screen (Φ8)**	BL50163521820	32	Oil seal	YR80554200000
	Screen (Φ10)**	BL50163521920	33	Left bearing plate	BH10162010010
	Screen (Φ12)**	BL50163521020	34	Material fender (65Mn)	YW45162850000
6	Castor	YW03000300000	35	Blade rest (1)	BH11162850010
7	Motor adjusting plate	-	36	Rotating balde**	YW42162840000
8	Base	-	37	Flat key 10X337	BH10163510010
9	Front pressure block	BH10163010010	38	Shaft	BH55163500010
10	Sustain brace**	YW41163520000	39	Sleeve	BH10161500010
11	Right end plate	BH10161600010	40	Back block	BH10163560010
12	Bearing cover	-	41	Pressure block of back block	BH10163550010
13	Bearing 6207DD*	YW11620700000	42	Front block	BW30163030010
14	Right bearing cover plate	-	43	Fixed castor 3"	YW03000300300
15	Taper sleeve 3020-35	YW30203500000	44	Movable castor 3"	YW03000300200
16	Large belt wheel	YW30231900000	45	Screen rest	-
17	Poly V-belt 20PJ50 *	YW30205000000	46	Safety switch installation shaft	BH10204300010
18	Outer shell	-	47	Blade rest 1	BH10116100010
19	Outer cover board of shell	-	48	Blade rest 2	BH10216200010
20	Upper cover board of shell	-	49	Blade rest 3	BH10316300010
21	Small belt pulley	YW30207800000	50	Blade rest (2)	BH11162050010
22	Ratating shaft	BH10204100010	51	Sleeve 1	BH10162823010
23	Star assembly of screen	BH55162820010	52	Taper sleeve 1210-28	YW30121002800
24	Check plate for storage box	-	53	Press block for rotating blade	BH11162700010

* means possible broken parts.

** means easy broken part. and spare backup is suggested.

Please confirm the version of manual before placing the purchase order to guarantee that the item number of the spare part is in accordance with the real object.

Table 2-4: Parts List (SG-1635NH)

No.	Name	Part No.	No.	Name	Part No.
1	Storage box	-	25	Motor (3.0kW)	YM10361900000
2	Knob	YR40083500000	26	Feeding box	-
3	Safety switch knob	BH10024200010	27	Star assembly of feeding box	BH55162800010
4	Safety switch installation board	BH10424500010	28	Handle*	BW20012000140
5	Screen (Φ4)**	BL50163521620	29	Feeding mouth	-
	Screen (Φ5)**	BL50162050020	30	Material fender	-
	Screen (Φ6)**	BL50163521720	31	Left bearing cover plate	-
	Screen (Φ8)**	BL50163521820	32	Oil seal	YR80554200000
	Screen (Φ10)**	BL50163521920	33	Left bearing plate	BH10162010010
	Screen (Φ12)**	BL50163521020	34	Material fender (65Mn)	YW45162850000
6	Castor	YW03000300000	35	Blade rest (1)	BH11162850010
7	Motor adjusting plate	-	36	Rotating balde**	YW42162840000
8	Base	-	37	Flat key 10X337	BH10163510010
9	Front pressure block	BH10163010010	38	Shaft	BH55163500010
10	Sustain brace**	YW41163520000	39	Sleeve	BH10161500010
11	Right end plate	BH10161600010	40	Back block	BH10163560010
12	Bearing cover	-	41	Pressure block of back block	BH10163550010
13	Bearing 6207DD*	YW11620700000	42	Front block	BW30163030010
14	Right bearing cover plate	-	43	Fixed castor 3"	YW03000300300
15	Taper sleeve 3020-35	YW30203500000	44	Movable castor 3"	YW03000300200
16	Large belt wheel	YW30231900000	45	Screen rest	-
17	Poly V-belt 20PJ50 *	YW30205000000	46	Safety switch installation shaft	BH10204300010
18	Outer shell	-	47	Blade rest 1	BH10116100010
19	Outer cover board of shell	-	48	Blade rest 2	BH10216200010
20	Upper cover board of shell	-	49	Blade rest 3	BH10316300010
21	Small belt pulley	YW30207800000	50	Blade rest (2)	BH11162050010
22	Rotating shaft	BH10204100010	51	Sleeve 1	BH10162823010
23	Star assembly of screen	BH55162820010	52	Taper sleeve 1210-28	YW30121002800
24	Check plate for storage box	-	53	Press block for rotating blade	BH11162700010

* means possible broken parts.

** means easy broken part. and spare backup is suggested.

Please confirm the version of manual before placing the purchase order to guarantee that the item number of the spare part is in accordance with the real object.

2.3.7 Assembly Drawing (SG-2028N(H))

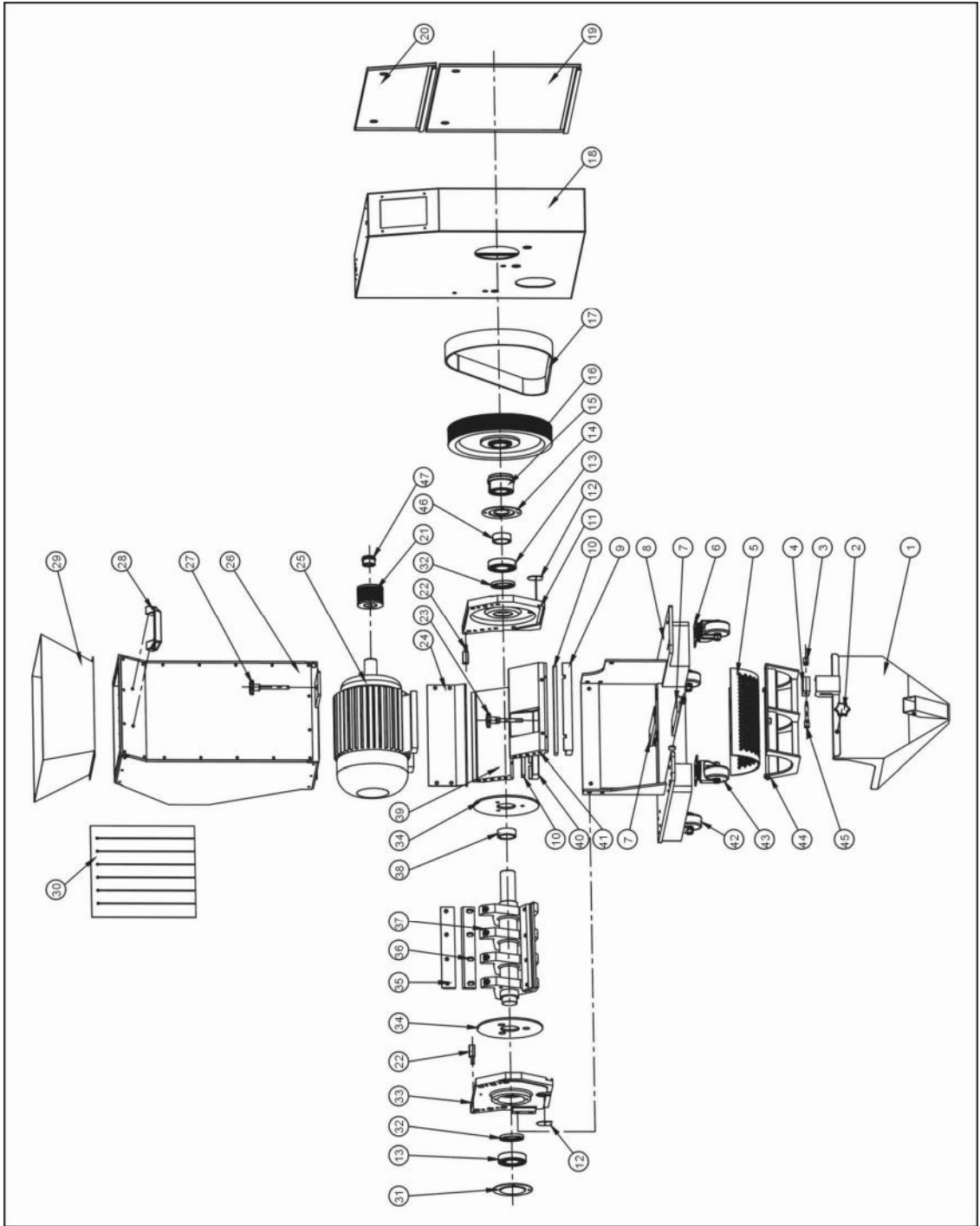

Note: Please refer to 2.3.8 material list about the parts code.

Picture 2-8: Assembly Drawing (SG-2028N(H))

2.3.8 Parts List (SG-2028N(H))

Table 2-5: Parts List (SG-2028N)

No.	Name	Part No.	No.	Name	Part No.
1	Material collection case	-	22	Rotating shaft	BH10204100010
2	Handle	YR40083500000	23	Star assembly of screen	BH10204220010
3	Safety switch handle	BH10024200010	24	Check plate for storage box	-
4	Safety switch installation board	BH10424500010	25	Motor (2.2kW)	YM10692900000
5	Screen (Φ4)**	BL50202810620	26	Feeding box	-
	Screen (Φ5)**	BL50202810720	27	Star assembly of feeding box	BH85204120010
	Screen (Φ6)**	BL55202850020	28	Handle *	BW20012000140
	Screen (Φ7)**	BL50202810820	29	Feeding mouth	-
	Screen (Φ8)**	BL50202810920	30	Material fender	-
	Screen (Φ10)**	BL50202811020	31	Cover board of left bearing plate	-
	Screen (Φ12)**	BL50202811120	32	Oil seal	YR80557200000
6	Castor with brake 3”	YW03000300000	33	Left bearing plate	BH10204210010
7	Adjusting board for motor	-	34	Material fender (65Mn)	BH11020020010
8	Motor base	-	35	Pressure block of balde	BH11202850010
9	Pressure block of front block	BH10202810010	36	Rotating blade**	YW43202800000
10	Fixed balde**	YW41202800000	37	Blade rest	BH11002028010
11	Right bearing holder	BH10204600010	38	Sleeve	BH10204500010
12	Cover board	-	39	Pressure block	BH10020208010
13	Bearing 6209DD*	YW11620900000	40	Pressure block of back block	BH10020270010
14	Right bearing cover plate	-	41	Front block	BH10202830010
15	Taper sleeve 3020-45	YW30302450000	42	Fixed castor 3”	YW03000300300
16	Large belt wheel	YW30231900000	43	Movable castor 3”	YW03000300200
17	Poly V-belt 20PJ53 *	YR00532000000	44	Screen rest	-
18	Out housing	-	45	Safety switch installation shaft	BH10204300010
19	Lower cover board of shell	-	46	Sleeve 1	BH10369002110
20	Upper cpver board of shell	-	47	Taper sleeve 1610-28	YW30121002800
21	Small belt pulley	YW30207800000			

* means possible broken parts.

** means easy broken part. and spare backup is suggested.

Please confirm the version of manual before placing the purchase order to guarantee that the item number of the spare part is in accordance with the real object.

Table 2-6: Parts List (SG-2028NH)

No.	Name	Part No.	No.	Name	Part No.
1	Material collection case	-	22	Rotating shaft	BH10204100010
2	Handle	YR40083500000	23	Star assembly of screen	BH10204220010
3	Safety switch handle	BH10024200010	24	Check plate for storage box	-
4	Safety switch installation board	BH10424500010	25	Motor (3.0kW)	YM10361900000
5	Screen (Φ4)**	BL50202810620	26	Feeding box	-
	Screen (Φ5)**	BL50202810720	27	Star assembly of feeding box	BH85204120010
	Screen (Φ6)**	BL55202850020	28	Handle *	BW20012000140
	Screen (Φ7)**	BL50202810820	29	Feeding mouth	-
	Screen (Φ8)**	BL50202810920	30	Material fender	-
	Screen (Φ10)**	BL50202811020	31	Cover board of left bearing plate	-
	Screen (Φ12)**	BL50202811120	32	Oil seal	YR80557200000
6	Castor with brake 3"	YW03000300000	33	Left bearing plate	BH10204210010
7	Adjusting board for motor	-	34	Material fender (65Mn)	BH11020020010
8	Motor base	-	35	Pressure block of balde	BH11202850010
9	Pressure block of front block	BH10202810010	36	Rotating blade**	YW43202800000
10	Fixed balde**	YW41202800000	37	Blade rest	BH11002028010
11	Right bearing holder	BH10204600010	38	Sleeve	BH10204500010
12	Cover board	-	39	Pressure block	BH10020208010
13	Bearing 6209DD*	YW11620900000	40	Pressure block of back block	BH10020270010
14	Right bearing cover plate	-	41	Front block	BH10202830010
15	Taper sleeve 3020-45	YW30302450000	42	Fixed castor 3"	YW03000300300
16	Large belt wheel	YW30231900000	43	Movable castor 3"	YW03000300200
17	Poly V-belt 20PJ53 *	YR00532000000	44	Screen rest	-
18	Out housing	-	45	Safety switch installation shaft	BH10204300010
19	Lower cover board of shell	-	46	Sleeve 1	BH10369002110
20	Upper cpver board of shell	-	47	Taper sleeve 1610-28	YW30121002800
21	Small belt pulley	YW30207800000			

* means possible broken parts.

** means easy broken part. and spare backup is suggested.

Please confirm the version of manual before placing the purchase order to guarantee that the item number of the spare part is in accordance with the real object.

2.3.9 Assembly Drawing (SG-2028NC(H))

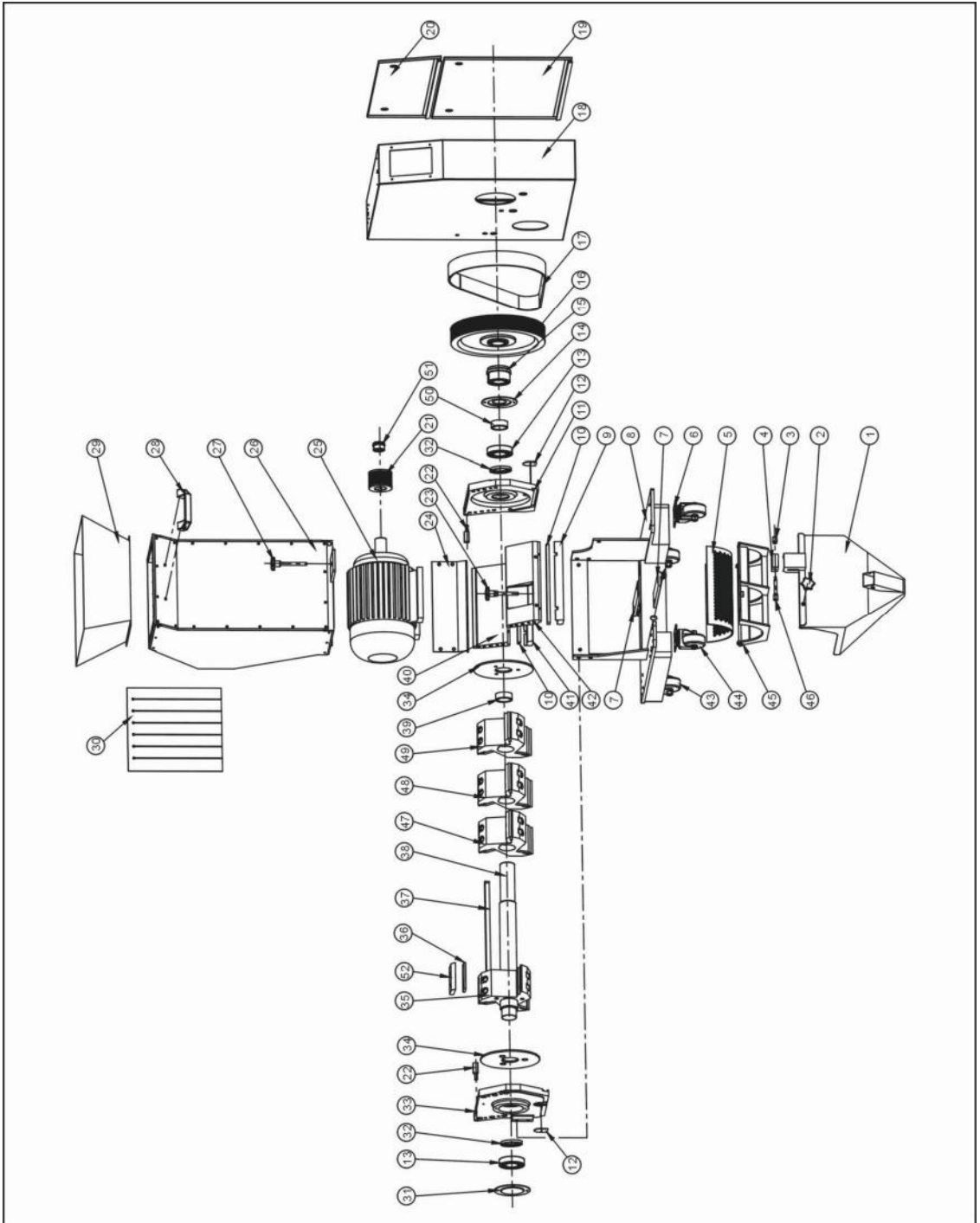

Note: Please refer to 2.3.10 material list about the parts code.

Picture 2-9: Assembly Drawing (SG-2028NC(H))

2.3.10 Parts List (SG-2028NC(H))

Table 2-7: Parts List (SG-2028NC)

No.	Name	Part No.	No.	Name	Part No.
1	Material collection case	-	24	Check plate for storage box	-
2	Handle	YR40083500000	25	Motor (2.2kW)	YM10692900000
3	Safety switch handle	BH10024200010	26	Feeding box	-
4	Safety switch installation board	BH10424500010	27	Star assembly of feeding box	BH85204120010
5	Screen (Φ4)**	BL50202810620	28	Handle *	BW20012000140
	Screen (Φ5)**	BL50202810720	29	Feeding mouth	-
	Screen (Φ6)**	BL55202850020	30	Material fender	-
	Screen (Φ7)**	BL50202810820	31	Cover board of left bearing plate	-
	Screen (Φ8)**	BL50202810920	32	Oil seal	YR80557200000
	Screen (Φ10)**	BL50202811020	33	Left bearing plate	BH10204210010
	Screen (Φ12)**	BL50202811120	34	Material fender (65Mn)	BH11020020010
6	Castor with brake 3"	YW03000300000	35	Blade rest 1	BW30200320010
7	Adjusting board for motor	-	36	Rotating blade**	BW41200100010
8	Motor base	-	37	Flat key 14X267	BH11202800310
9	Pressure block of front block	BH10202810010	38	Shaft	BH11202810010
10	Fixed balde**	YW41202800000	39	Sleeve	BH10204500010
11	Right bearing holder	BH10204600010	40	Pressure block	BH10020208010
12	Cover board	-	41	Pressure block of back block	BH10020270010
13	Bearing 6209DD*	YW11620900000	42	Front block	BH10202830010
14	Right bearing cover plate	-	43	Fixed castor 3"	YW03000300300
15	Taper sleeve 3020-45	YW30302450000	44	Movable castor 3"	YW03000300200
16	Large belt wheel	YW30231900000	45	Screen rest	-
17	Poly V-belt 20PJ53 *	YR00532000000	46	Safety switch installation shaft	BH10204300010
18	Out housing	-	47	Blade rest 2	BW30202420010
19	Lower cover board of shell	-	48	Blade rest 3	BW30200520010
20	Upper cpver board of shell	-	49	Blade rest 4	BW30202800210
21	Small belt pulley	YW30209800000	50	Sleeve 1	BH10369002110
22	Rotating shaft	BH10204100010	51	Taper sleeve 1610-28	YW30162800200
23	Star assembly of screen	BH10204220010	52	Press block for rotating blade	BH10235200010

* means possible broken parts.

** means easy broken part. and spare backup is suggested.

Please confirm the version of manual before placing the purchase order to guarantee that the item number of the spare part is in accordance with the real object.

Table 2-8: Parts List (SG-2028NCH)

No.	Name	Part No.	No.	Name	Part No.
1	Material collection case	-	24	Check plate for storage box	-
2	Handle	YR40083500000	25	Motor (3.0kW)	YM10361900000
3	Safety switch handle	BH10024200010	26	Feeding box	-
4	Safety switch installation board	BH10424500010	27	Star assembly of feeding box	BH85204120010
5	Screen (Φ4)**	BL50202810620	28	Handle *	BW20012000140
	Screen (Φ5)**	BL50202810720	29	Feeding mouth	-
	Screen (Φ6)**	BL55202850020	30	Material fender	-
	Screen (Φ7)**	BL50202810820	31	Cover board of left bearing plate	-
	Screen (Φ8)**	BL50202810920	32	Oil seal	YR80557200000
	Screen (Φ10)**	BL50202811020	33	Left bearing plate	BH10204210010
	Screen (Φ12)**	BL50202811120	34	Material fender (65Mn)	BH11020020010
6	Castor with brake 3"	YW03000300000	35	Blade rest 1	BW30200320010
7	Adjusting board for motor	-	36	Rotating blade**	BW41200100010
8	Motor base	-	37	Flat key 14X267	BH11202800310
9	Pressure block of front block	BH10202810010	38	Shaft	BH11202810010
10	Fixed balde**	YW41202800000	39	Sleeve	BH10204500010
11	Right bearing holder	BH10204600010	40	Pressure block	BH10020208010
12	Cover board	-	41	Pressure block of back block	BH10020270010
13	Bearing 6209DD*	YW11620900000	42	Front block	BH10202830010
14	Right bearing cover plate	-	43	Fixed castor 3"	YW03000300300
15	Taper sleeve 3020-45	YW30302450000	44	Movable castor 3"	YW03000300200
16	Large belt wheel	YW30231900000	45	Screen rest	-
17	Poly V-belt 20PJ53 *	YR00532000000	46	Safety switch installation shaft	BH10204300010
18	Out housing	-	47	Blade rest 2	BW30202420010
19	Lower cover board of shell	-	48	Blade rest 3	BW30200520010
20	Upper cpver board of shell	-	49	Blade rest 4	BW30202800210
21	Small belt pulley	YW30209800000	50	Sleeve 1	BH10369002110
22	Rotating shaft	BH10204100010	51	Taper sleeve 1610-28	YW30162800200
23	Star assembly of screen	BH10204220010	52	Press block for rotating blade	BH10235200010

* means possible broken parts.

** means easy broken part. and spare backup is suggested.

Please confirm the version of manual before placing the purchase order to guarantee that the item number of the spare part is in accordance with the real object.

2.3.11 Assembly Drawing (SG-2042N(H))

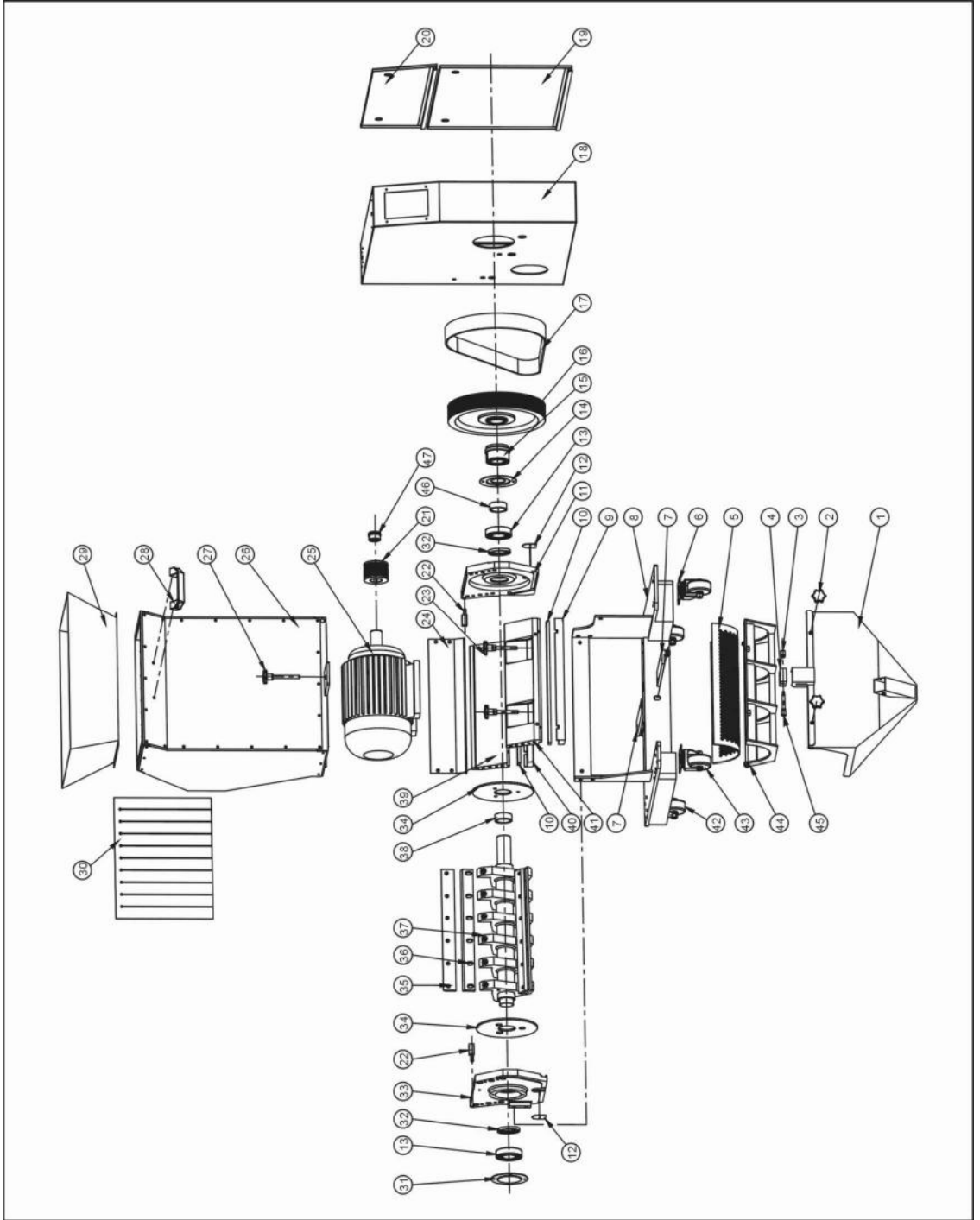

Note: Please refer to 2.3.12 material list about the parts code.

Picture 2-10: Assembly Drawing (SG-2042N(H))

2.3.12 Parts List (SG-2042N(H))

Table 2-9: Parts List (SG-2042N)

No.	Name	Part No.	No.	Name	Part No.
1	Material collection case	-	22	Rotating shaft	BH10204100010
2	Handle	YR40083500000	23	Star assembly of screen	BH10204220010
3	Safety switch handle	BH10024200010	24	Check plate for storage box	-
4	Safety switch installation board	BH10424500010	25	Motor (3.0kW)	YM10361900000
5	Screen (Φ4)**	BL50202811620	26	Feeding box	-
	Screen (Φ5)**	BL50202811720	27	Star assembly of feeding box	BH85204120010
	Screen (Φ6)**	BL55204260020	28	Handle *	BW20012000140
	Screen (Φ7)**	BL50202811820	29	Feeding mouth	-
	Screen (Φ8)**	BL50202811920	30	Material fender	-
	Screen (Φ10)**	BL50202812020	31	Cover board of left bearing plate	-
	Screen (Φ12)**	BL50202812120	32	Oil seal	YR80557200000
6	Castor with brake 3"	YW03000300000	33	Left bearing plate	BH10204210010
7	Adjusting board for motor	-	34	Material fender (65Mn)	BH11020020010
8	Motor base	-	35	Pressure block of balde	BH11204250010
9	Pressure block of front block	BH10235000010	36	Rotating blade**	YW43204200000
10	Fixed balde**	YW41041900000	37	Blade rest	BH11204260010
11	Right bearing holder	BH10204600010	38	Sleeve	BH10204500010
12	Cover board	-	39	Pressure block	BH10204290010
13	Bearing 6209DD*	YW11620900000	40	Pressure block of back block	BH10024280010
14	Right bearing cover plate	-	41	Front block	BH10204230010
15	Taper sleeve 3020-45	YW30302450000	42	Fixed castor 3"	YW03000300300
16	Large belt wheel	YW30231900000	43	Movable castor 3"	YW03000300200
17	Poly V-belt 20PJ53 *	YW30253300000	44	Screen rest	-
18	Out housing	-	45	Safety switch installation shaft	BH10204300010
19	Lower cover board of shell	-	46	Sleeve 1	BH10369002110
20	Upper cpver board of shell	-	47	Taper sleeve 1610-38	YW30163800000
21	Small belt pulley	YW30209800000			

* means possible broken parts.

** means easy broken part. and spare backup is suggested.

Please confirm the version of manual before placing the purchase order to guarantee that the item number of the spare part is in accordance with the real object.

Table 2-10: Parts List (SG-2042NH)

No.	Name	Part No.	No.	Name	Part No.
1	Material collection case	-	22	Rotating shaft	BH10204100010
2	Handle	YR40083500000	23	Star assembly of screen	BH10204220010
3	Safety switch handle	BH10024200010	24	Check plate for storage box	-
4	Safety switch installation board	BH10424500010	25	Motor (4.0kW)	YM10113300000
5	Screen (Φ4)**	BL50202811620	26	Feeding box	-
	Screen (Φ5)**	BL50202811720	27	Star assembly of feeding box	BH85204120010
	Screen (Φ6)**	BL55204260020	28	Handle *	BW20012000140
	Screen (Φ7)**	BL50202811820	29	Feeding mouth	-
	Screen (Φ8)**	BL50202811920	30	Material fender	-
	Screen (Φ10)**	BL50202812020	31	Cover board of left bearing plate	-
	Screen (Φ12)**	BL50202812120	32	Oil seal	YR80557200000
6	Castor with brake 3"	YW03000300000	33	Left bearing plate	BH10204210010
7	Adjusting board for motor	-	34	Material fender (65Mn)	BH11020020010
8	Motor base	-	35	Pressure block of balde	BH11204250010
9	Pressure block of front block	BH10235000010	36	Rotating blade**	YW43204200000
10	Fixed balde**	YW41041900000	37	Blade rest	BH11204260010
11	Right bearing holder	BH10204600010	38	Sleeve	BH10204500010
12	Cover board	-	39	Pressure block	BH10204290010
13	Bearing 6209DD*	YW11620900000	40	Pressure block of back block	BH10024280010
14	Right bearing cover plate	-	41	Front block	BH10204230010
15	Taper sleeve 3020-45	YW30302450000	42	Fixed castor 3"	YW03000300300
16	Large belt wheel	YW30231900000	43	Movable castor 3"	YW03000300200
17	Poly V-belt 20PJ53 *	YW30253300000	44	Screen rest	-
18	Out housing	-	45	Safety switch installation shaft	BH10204300010
19	Lower cover board of shell	-	46	Sleeve 1	BH10369002110
20	Upper cpver board of shell	-	47	Taper sleeve 1610-38	YW30163800000
21	Small belt pulley	YW30209800000			

* means possible broken parts.

** means easy broken part. and spare backup is suggested.

Please confirm the version of manual before placing the purchase order to guarantee that the item number of the spare part is in accordance with the real object.

2.3.13 Assembly Drawing (SG-2042NC(H))

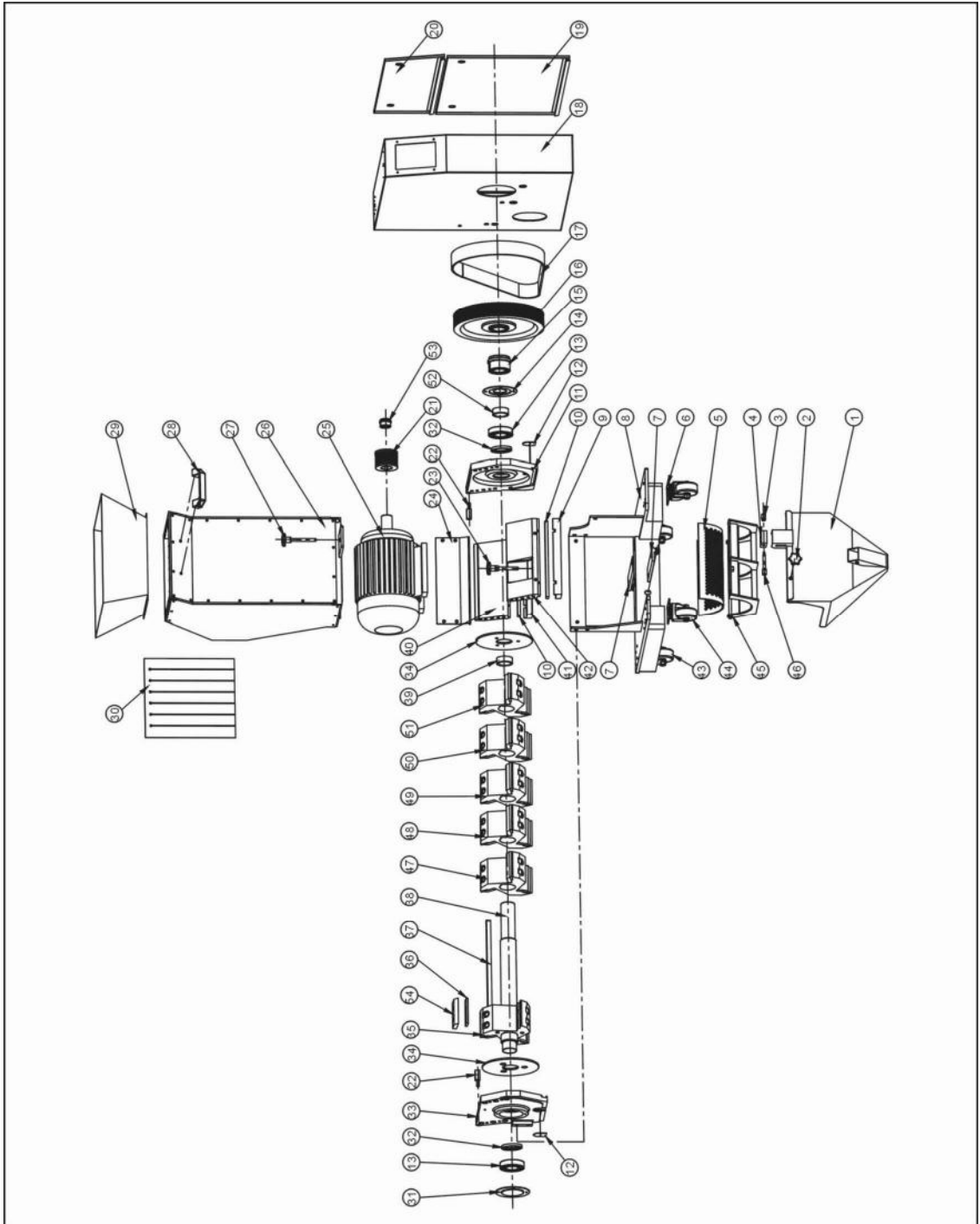

Note: Please refer to 2.3.14 material list about the parts code.

Picture 2-11: Assembly Drawing (SG-2042NC(H))

2.3.14 Parts List (SG-2042NC(H))

Table 2-11: Parts List (SG-2042NC)

No.	Name	Part No.	No.	Name	Part No.
1	Material collection case	-	25	Motor (3.0kW)	YM10713000800
2	Handle	YR40083500000	26	Feeding box	-
3	Safety switch handle	BH10024200010	27	Star assembly of feeding box	BH85204120010
4	Safety switch installation board	BH10424500010	28	Handle *	BW20012000140
5	Screen (Φ4)**	BL50202811620	29	Feeding mouth	-
	Screen (Φ5)**	BL50202811720	30	Material fender	-
	Screen (Φ6)**	BL55204260020	31	Cover board of left bearing plate	-
	Screen (Φ7)**	BL50202811820	32	Oil seal	YR80557200000
	Screen (Φ8)**	BL50202811920	33	Left bearing plate	BH10204210010
	Screen (Φ10)**	BL50202812020	34	Material fender (65Mn)	BH11020020010
	Screen (Φ12)**	BL50202812120	35	Blade rest 1	BW30200320010
6	Castor with brake 3"	YW03000300000	36	Rotating blade**	BW41200100010
7	Adjusting board for motor	-	37	Flat key 14X267	BH11204200510
8	Motor base	-	38	Shaft	BH11204210110
9	Pressure block of front block	BH10235000010	39	Sleeve	BH10204500010
10	Fixed balde**	YW41041900000	40	Pressure block	BH10204290010
11	Right bearing holder	BH10204600010	41	Pressure block of back block	BH10024280010
12	Cover board	-	42	Front block	BH10204230010
13	Bearing 6209DD*	YW11620900000	43	Fixed castor 3"	YW03000300300
14	Right bearing cover plate	-	44	Movable castor 3"	YW03000300200
15	Taper sleeve 3020-45	YW30302450000	45	Screen rest	-
16	Large belt wheel	YW30231900000	46	Safety switch installation shaft	BH10204300010
17	Poly V-belt 20PJ53 *	YW30253300000	47	Blade rest 2	BW30202420010
18	Out housing	-	48	Blade rest 3	BW30200520010
19	Lower cover board of shell	-	49	Blade rest 4	BW30204220210
20	Upper cpver board of shell	-	50	Blade rest 5	BW30204220310
21	Small belt pulley	YW30209800000	51	Blade rest 6	BW30204220410
22	Rotating shaft	BH10204100010	52	Sleeve 1	BH10369002110
23	Star assembly of screen	BH10204220010	53	Taper sleeve 1610-38	YW30163800000
24	Check plate for storage box	-	54	Press block for rotating blade	BH10235200010

* means possible broken parts. ** means easy broken part. and spare backup is suggested. Please confirm the version of manual before placing the purchase order to guarantee that the item number of the spare part is in accordance with the real object.

Table 2-12: Parts List (SG-2042NCH)

No.	Name	Part No.	No.	Name	Part No.
1	Material collection case	-	25	Motor (4.0kW)	YM10713300600
2	Handle	YR40083500000	26	Feeding box	-
3	Safety switch handle	BH10024200010	27	Star assembly of feeding box	BH85204120010
4	Safety switch installation board	BH10424500010	28	Handle *	BW20012000140
5	Screen (Φ4)**	BL50202811620	29	Feeding mouth	-
	Screen (Φ5)**	BL50202811720	30	Material fender	-
	Screen (Φ6)**	BL55204260020	31	Cover board of left bearing plate	-
	Screen (Φ7)**	BL50202811820	32	Oil seal	YR80557200000
	Screen (Φ8)**	BL50202811920	33	Left bearing plate	BH10204210010
	Screen (Φ10)**	BL50202812020	34	Material fender (65Mn)	BH11020020010
	Screen (Φ12)**	BL50202812120	35	Blade rest 1	BW30200320010
6	Castor with brake 3"	YW03000300000	36	Rotating blade**	BW41200100010
7	Adjusting board for motor	-	37	Flat key 14X267	BH11204200510
8	Motor base	-	38	Shaft	BH11204210110
9	Pressure block of front block	BH10235000010	39	Sleeve	BH10204500010
10	Fixed balde**	YW41041900000	40	Pressure block	BH10204290010
11	Right bearing holder	BH10204600010	41	Pressure block of back block	BH10024280010
12	Cover board	-	42	Front block	BH10204230010
13	Bearing 6209DD*	YW11620900000	43	Fixed castor 3"	YW03000300300
14	Right bearing cover plate	-	44	Movable castor 3"	YW03000300200
15	Taper sleeve 3020-45	YW30302450000	45	Screen rest	-
16	Large belt wheel	YW30231900000	46	Safety switch installation shaft	BH10204300010
17	Poly V-belt 20PJ53 *	YW30253300000	47	Blade rest 2	BW30202420010
18	Out housing	-	48	Blade rest 3	BW30200520010
19	Lower cover board of shell	-	49	Blade rest 4	BW30204220210
20	Upper cpver board of shell	-	50	Blade rest 5	BW30204220310
21	Small belt pulley	YW30209800000	51	Blade rest 6	BW30204220410
22	Rotating shaft	BH10204100010	52	Sleeve 1	BH10369002110
23	Star assembly of screen	BH10204220010	53	Taper sleeve 1610-38	YW30163800000
24	Check plate for storage box	-	54	Press block for rotating blade	BH10235200010

* means possible broken parts.

** means easy broken part. and spare backup is suggested.

Please confirm the version of manual before placing the purchase order to guarantee that the item number of the spare part is in accordance with the real object.

2.3.15 Cutting Chamber

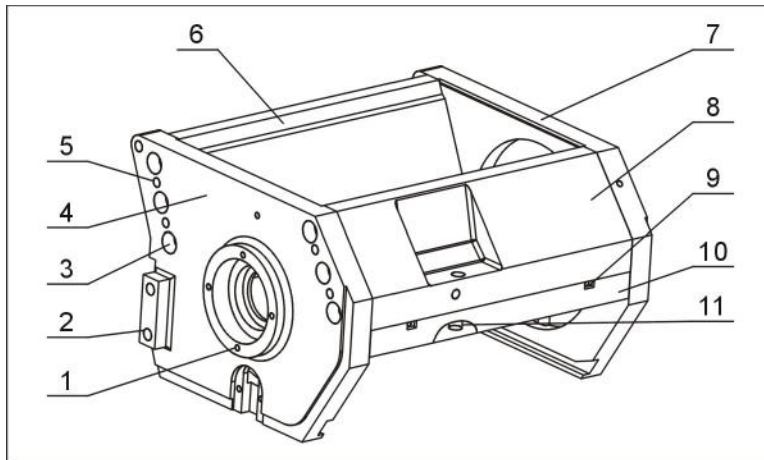

Picture 2-12: Cutting Chamber

2.3.16 Cutting Chamber Parts List

Table 2-13: Cutting Chamber Parts List

No.	Name	Quantity
1	Cross socket head cap screw M5×10	12
2	Inner hexagonal column bolt M10×20	5
3	Inner hexagonal column bolt M10×35	12
4	Left bearing holder	1
5	Flexible column pin 8×35	8
6	Back block	1
7	Right bearing holder	1
8	Front block	1
9	Inner hexagonal set screw M5×16 (SG-20)	4
	Inner hexagonal set screw M4×16 (SG-16)	4
10	Pressure block of front block	1
11	Inner hexagonal column bolt M10×25 (SG-20)	6-8
	Inner hexagonal column bolt M8×25 (SG-16)	6-8

2.3.17 Blade Rest

2.3.17.1 Staggered Blade Rest

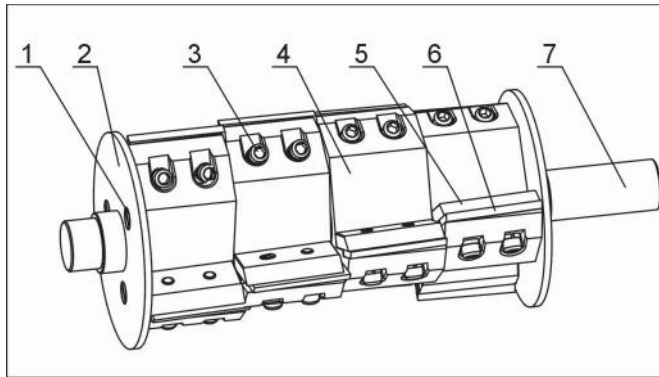

Picture 2-13: Staggered Blade Rest

2.3.17.2 Staggered Blade Rest Parts List

Table 2-14: Staggered Blade Rest Parts List

No.	Name	Quantity
1	Inner hexagonal countersunk bolt M8×12	6
2	Material fender	2
3	Inner hexagon cylindrical screw M8×30	18-24-30
4	Blade rest	3-4-5
5	Blade fastener	9-12-15
6	Rotating blade	9-12-15
7	Main shaft	1

2.3.17.3 Paddle Blade Rest

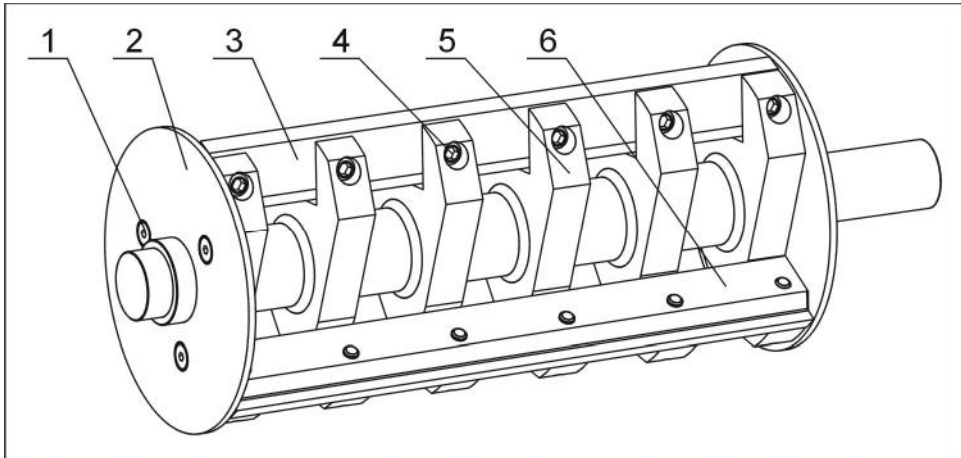

Picture 2-14: Paddle Blade Rest

2.3.17.4 Paddle Blade Rest Parts List

Table 2-15: Paddle Blade Rest Parts List

No.	Name	Quantity
1	Inner hexagonal countersunk bolt M8×12	6
2	Material fender	2
3	Rotating blade	3
4	Inner hexagon cylindrical screw M10×35	12-18
5	Main shaft	1
6	Blade pressing plate	3

2.3.18 Transmission Parts

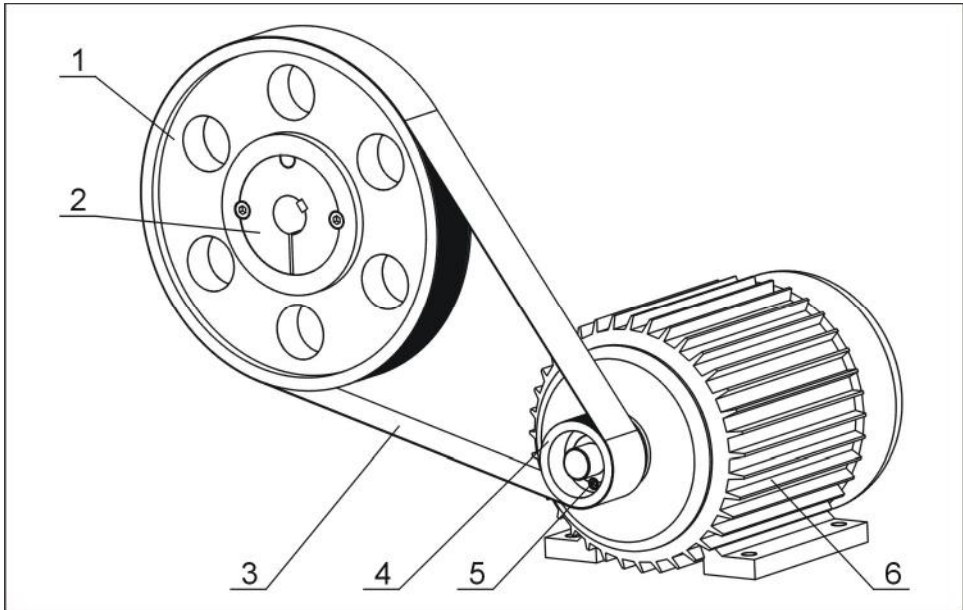

Picture 2-15: Transmission Parts

2.3.19 Transmission Parts Parts List

Table 2-16: Transmission Parts Parts List

No.	Name	Quantity
1	Big belt pulley	1
2	Taper sleeve	1
3	V belt 20 PJ 53" (SG-20)	1
	V belt 20 PJ 50" (SG-16)	1
4	Motor belt pulley	1
5	Taper sleeve	1
6	Motor	1

2.3.20 Feed Port, Feed Box and Material Check Plate

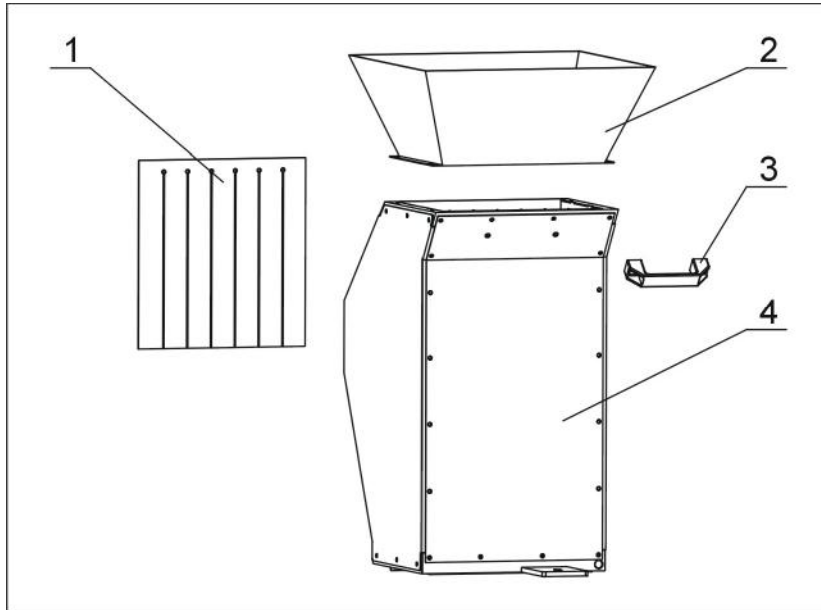

Picture 2-16: Feed Port, Feed Box and Material Check Plate

2.3.21 Feed Port, Feed Box and Material Check Plate Parts List

Table 2-17: Feed Port, Feed Box and Material Check Plate Parts List

No.	Name	Quantity
1	Material fender	1
2	Feed opening	1
3	Handle	1
4	Feed box	1

2.3.22 Screen and Screen Frame

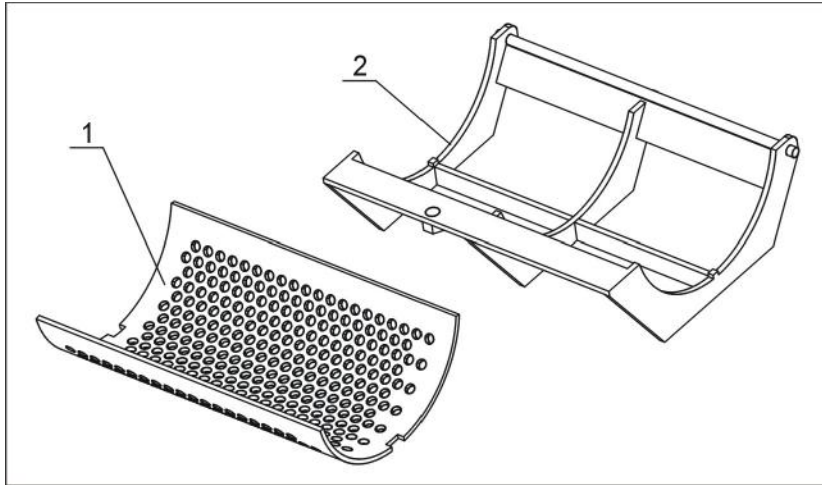

Picture 2-17: Screen and Screen Frame

2.3.23 Screen and Screen Frame Parts List

Table 2-18: Screen and Screen Frame Parts List

No.	Name	Quantity
1	Screen	1
2	Screen bracket	1

2.4 Electrical Diagram

2.4.1 Electrical Circuit (400V)

Table 2-19: Electrical Circuit (400V)

SYMBOL MODE	(a)	(b)	(c)	(d)	(e)	(f)	(g)	(h)	(i)	(j)	(k)	(l)	(m)	(n)	(o)
SG-1621N	4.6	2.5	16	10	3.2-5.0	4.0	2.2	1.5	3.6	5	1.0-1.6	1.1	2.5	0.37	1.0
SG-1628NS	4.6	2.5	16	10	3.2-5.0	4.0	2.2	1.5	3.6	5	1.0-1.6	1.1	2.5	0.37	1.0
SG-1628N	6.2	2.5	16	10	4.0-6.3	5.7	2.2	2.2	5.2	5	1.0-1.6	1.1	2.5	0.37	1.0
SG-1635N	6.2	2.5	16	10	4.0-6.3	5.7	2.2	2.2	5.2	5	1.0-1.6	1.1	2.5	0.37	1.0
SG-2028N	6.2	2.5	16	10	4.0-6.3	5.7	2.2	2.2	5.2	5	1.0-1.6	1.1	2.5	0.37	1.0
SG-1635NH	8.2	2.5	16	15	6.3-10.0	7.9	2.2	3.0	7.2	5	1.0-1.6	1.1	2.5	0.37	1.0
SG-2028NH	8.2	2.5	16	15	6.3-10.0	7.9	2.2	3.0	7.2	5	1.0-1.6	1.1	2.5	0.37	1.0
SG-2042N	8.2	2.5	16	15	6.3-10.0	7.9	2.2	3.0	7.2	5	1.0-1.6	1.1	2.5	0.37	1.0
SG-2042NH	10.2	2.5	16	20	8-12.5	10.0	2.2	4.0	9.2	5	1.0-1.6	1.1	2.5	0.37	1.0

- (a) Main current
- (b) Main power cable dia.
- (c) Main rating current
- (d) Grinding motor circuit breaker
- (e) Grinding motor overload relay
- (f) Grinding motor overload relay setting value
- (g) Grinding motor cable dia.
- (h) Grinding motor power
- (i) Grinding motor current
- (j) Grinding motor circuit breaker
- (k) Conveying blower overload relay
- (l) Conveying blower overload relay setting value
- (m) Conveying motor cable Dia.
- (n) Conveying blower power
- (o) Conveying blower current

2.4.2 Main Circuit (400V)

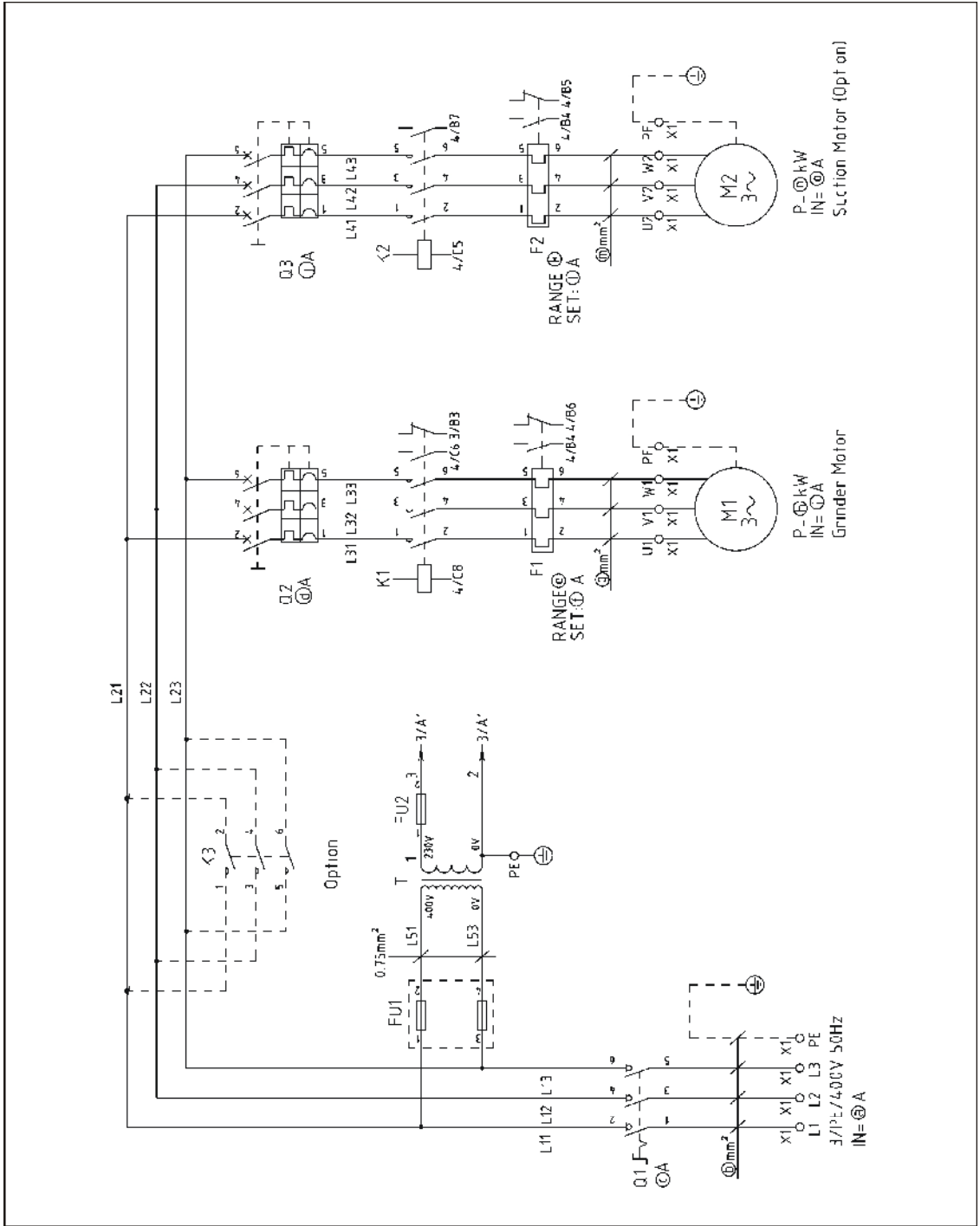

Picture 2-18: Main Circuit 1(400V)

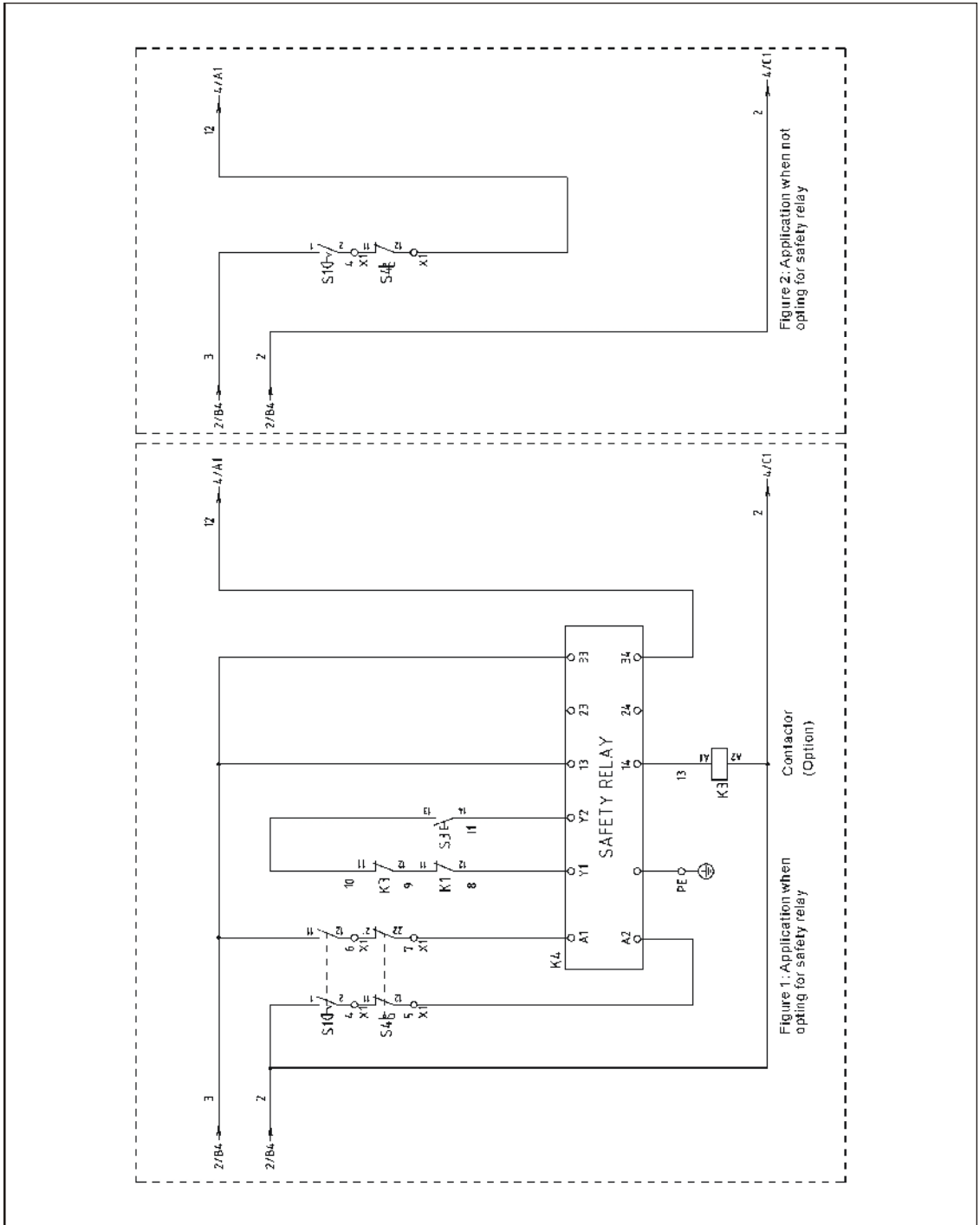

Picture 2-19: Main Circuit 2(400V)

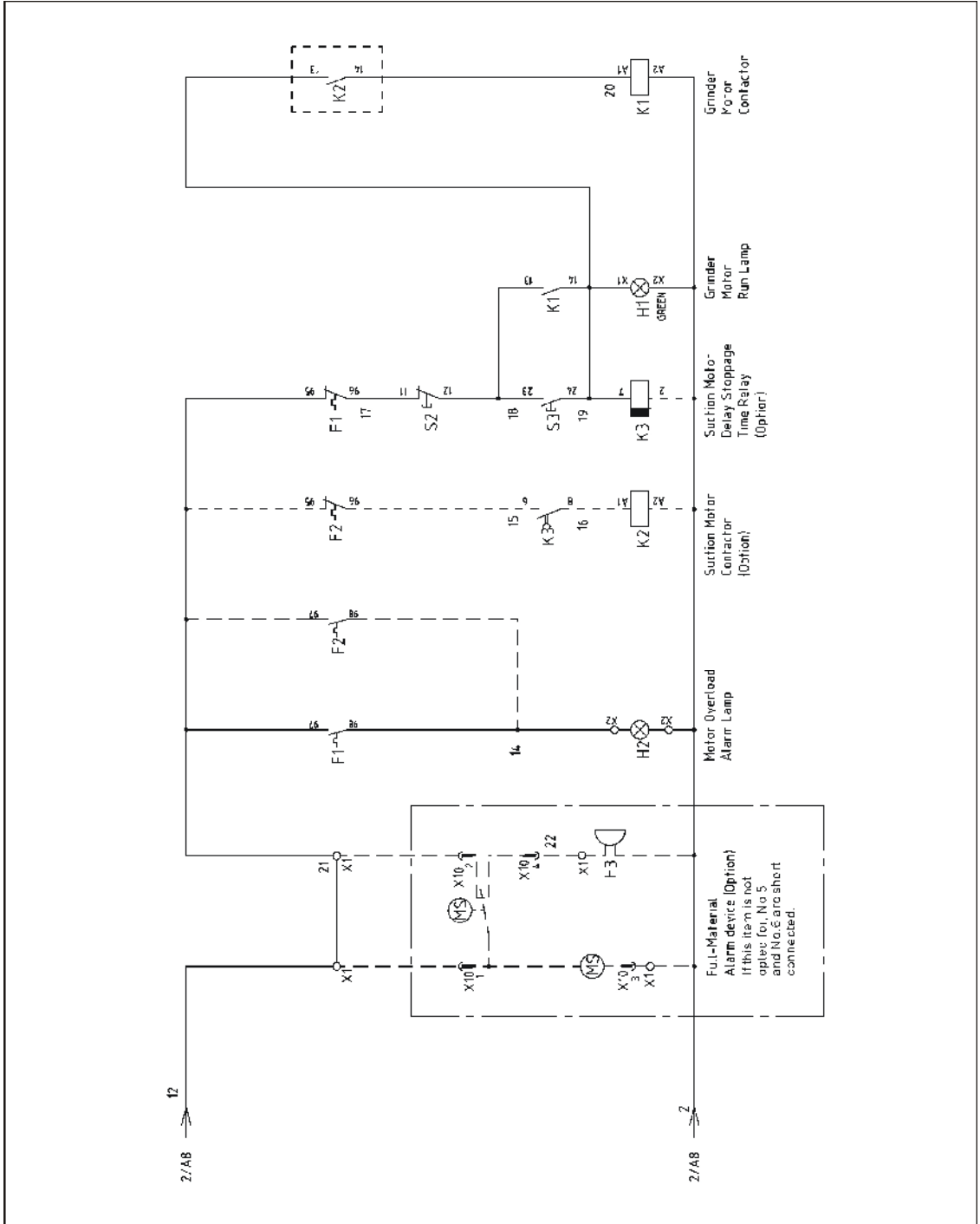

Picture 2-20: Main Circuit 3(400V)

2.4.3 Components Layout (400V)

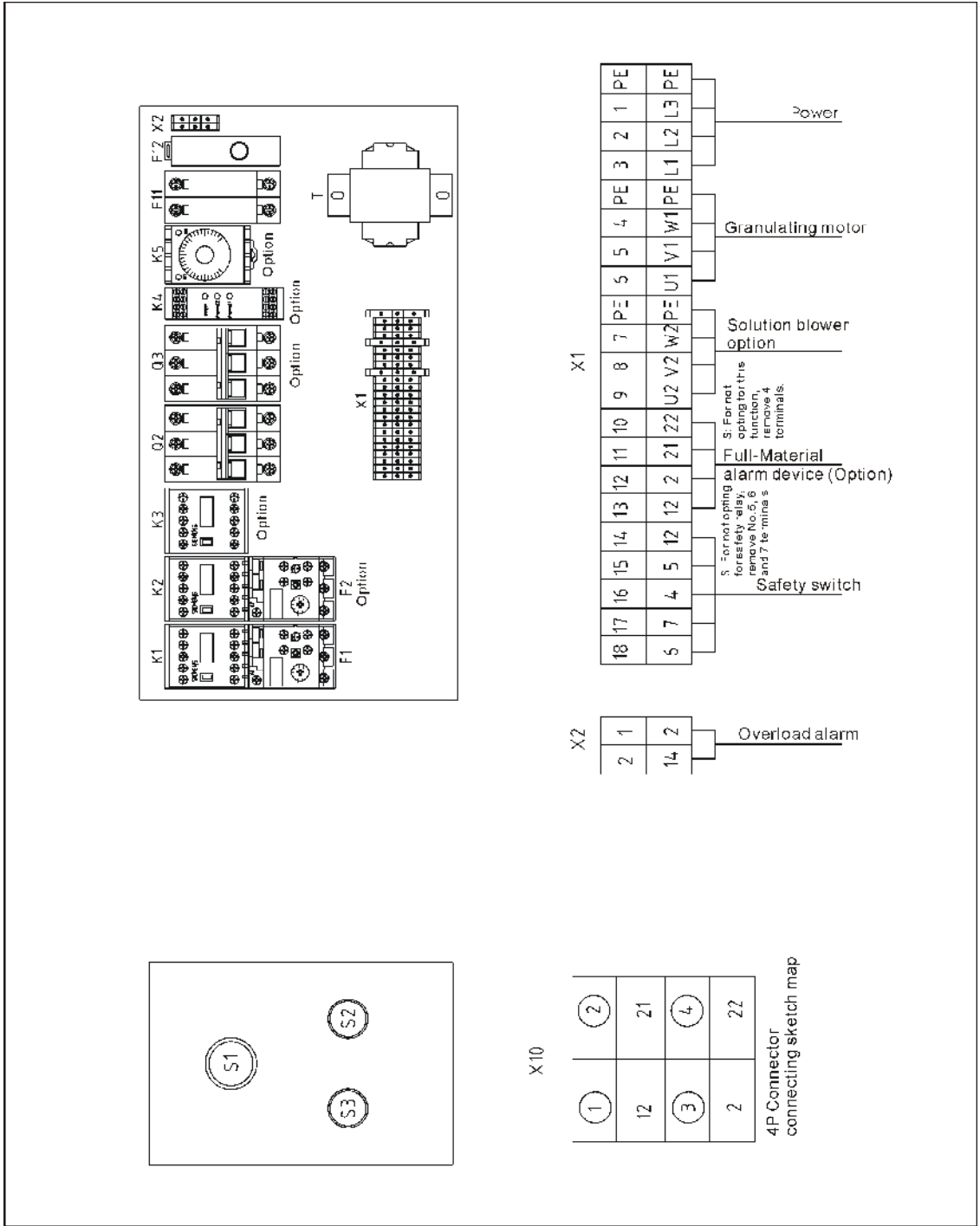

Picture 2-21: Components Layout (400V)

2.4.4 Electrical Components List (400V)

Table 2-20: Electrical Components List of SG-1621N (400V)

NO.	Symbol	Name	Specification	Part NO.
1	Q1	Main switch	16A	YE10021160000
2	Q2	Circuit breaker*	10A	YE40600300000
3	Q3	Circuit breaker*	5A	YE40603000000
4	K1	Contactor*	230V 50/60Hz	YE00311000000
5	-	Auxiliary contact terminal	1NC	YE00400100200
6	K2	Contactor*	230V 50/60Hz	YE00311000000
7	K3	Contactor*	230V 50/60Hz	YE00310100000
8	K4	Safety relay	230VAC	YE04372100000
9	K5	Time relay	230VAC	YE86322000000
10	F1	Overload relay*	3.2~5A	YE01032500000
11	F2	Overload relay*	1~1.6A	YE01011600000
12	T	Transformer*	400V/230V 300mA	YE70402300700
13	FU1	Fuse**	2P	YE41032200000
14	-	Fuse core	1A	YE46001000100
15	FU2	Fuse**	2A	YE41001000000
16	X1	Terminal board	32A	YE61250040000
17	-	-	-	YE61253500000
18	-	Terminal board	32A	YE61250040000
19	-	-	-	YE61253500000
20	-	Terminal board	32A	YE61250040000
21	X2	Terminal board	32A	YE61250040000
22	H2	Indicate lamp	220VA	YE83305100200
23	X10	Metal tie in	4P	YE68025400000
24	-	-	4P	YE68025400100
25	S1	Emergency stop button	400VAC	YE11320300000
26	-	Contact block	1NC	YE19340000100
27	S2	Stop button	400VAC	YE11375800000
28	S3 H1	Start button	400VAC	YE11325300000
29	-	Contact block	1NO	YE19340000000
30	S4	Safety switch	AZ-17	-
31	H3	Buzzer	220VAC	YE84222000000
32	MS	Feed position motor	3A/25V	YE15000200100
33	M1	Granulating motor	400V 50/60Hz 1.5kW	-

NO.	Symbol	Name	Specification	Part NO.
34	M2	Solution blower	400V 50/60Hz 0.37kW	-

* means possible broken parts.

** means easy broken part. and spare backup is suggested.

Please confirm the version of manual before placing the purchase order to guarantee that the item number of the spare part is in accordance with the real object.

Table 2-21: Electrical Components List of SG-1628N/1635N/2028N (400V)

NO.	Symbol	Name	Specification	Part NO.
1	Q1	Main switch	16A	YE10021160000
2	Q2	Circuit breaker*	10A	YE40600300000
3	Q3	Circuit breaker*	5A	YE40603000000
4	K1	Contactorm*	230V 50/60Hz	YE00311000000
5	-	Auxiliary contact terminal	1NC	YE00400100200
6	K2	Contactorm*	230V 50/60Hz	YE00311000000
7	K3	Contactorm*	230V 50/60Hz	YE00310100000
8	K4	Safety relay	230VAC	YE04372100000
9	K5	Time relay	230VAC	YE86322000000
10	F1	Overload relay*	4~6.3A	YE01046300100
11	F2	Overload relay*	1~1.6A	YE01011600000
12	T	Transformer*	400V/230V 300mA	YE70402300700
13	FU1	Fuse**	2P	YE41032200000
14	-	Fuse core	1A	YE46001000100
15	FU2	Fuse**	2A	YE41001000000
16	X1	Terminal board	32A	YE61250040000
17	-	-	-	YE61253500000
18	-	Terminal board	32A	YE61250040000
19	-	-	-	YE61253500000
20	-	Terminal board	32A	YE61250040000
21	X2	Terminal board	32A	YE61250040000
22	H2	Indicate lamp	220VA	YE83305100200
23	X10	Metal rie in	4P	YE68025400000
24	-	-	4P	YE68025400100
25	S1	Emergency stop button	400VAC	YE11320300000
26	-	Contact block	1NC	YE19340000100
27	S2	Stop button	400VAC	YE11375800000
28	S3 H1	Start button	400VAC	YE11325300000
29	-	Contact block	1NO	YE19340000000
30	S4	Safety switch	AZ-17	-
31	H3	Buzzer	220VAC	YE84222000000
32	MS	Feed position motor	3A/25V	YE15000200100
33	M1	Granulating motor	400V 50/60Hz 2.2kW	-
34	M2	Solution blower	400V 50/60Hz 0.37kW	-

Table 2-22: Electrical Components List of SG-1635NH/2028NH/2042N (400V)

NO.	Symbol	Name	Specification	Part NO.
1	Q1	Main switch	16A	YE10021160000
2	Q2	Circuit breaker*	15A	YE40601500000
3	Q3	Circuit breaker*	5A	YE40603000000
4	K1	Contactor*	230V 50/60Hz	YE00311000000
5	-	Auxiliary contact terminal	1NC	YE00400100200
6	K2	Contactor*	230V 50/60Hz	YE00311000000
7	K3	Contactor*	230V 50/60Hz	YE00310100000
8	K4	Safety relay	230VAC	YE04372100000
9	K5	Time relay	230VAC	YE86322000000
10	F1	Overload relay*	6.3~10A	YE01631000000
11	F2	Overload relay*	1~1.6A	YE01011600000
12	T	Transformer*	400V/230V 300mA	YE70402300700
13	FU1	Fuse**	2P	YE41032200000
14	-	Fuse core	1A	YE46001000100
15	FU2	Fuse**	2A	YE41001000000
16	X1	Terminal board	32A	YE61250040000
17	-	-	-	YE61253500000
18	-	Terminal board	32A	YE61250040000
19	-	-	-	YE61253500000
20	-	Terminal board	32A	YE61250040000
21	X2	Terminal board	32A	YE61250040000
22	H2	Indicate lamp	220VA	YE83305100200
23	X10	Metal tie in	4P	YE68025400000
24	-	-	4P	YE68025400100
25	S1	Emergency stop button	400VAC	YE11320300000
26	-	Contact block	1NC	YE19340000100
27	S2	Stop button	400VAC	YE11375800000
28	S3 H1	Start button	400VAC	YE11325300000
29	-	Contact block	1NO	YE19340000000
30	S4	Safety switch	AZ-17	-
31	H3	Buzzer	220VAC	YE84222000000
32	MS	Feed position motor	3A/25V	YE15000200100
33	M1	Granulating motor	400V 50/60Hz 3.0kW	-
34	M2	Solution blower	400V 50/60Hz 0.37kW	-

Table 2-23: Electrical Components List of SG-2042NH (400V)

NO.	Symbol	Name	Specification	Part NO.
1	Q1	Main switch	16A	YE10021160000
2	Q2	Circuit breaker*	20A	YE40602000000
3	Q3	Circuit breaker*	5A	YE40603000000
4	K1	Contactora*	230V 50/60Hz	YE00311000000
5	-	Auxiliary contact terminal	1NC	YE00400100200
6	K2	Contactora*	230V 50/60Hz	YE00311000000
7	K3	Contactora*	230V 50/60Hz	YE00310100000
8	K4	Safety relay	230VAC	YE04372100000
9	K5	Time relay	230VAC	YE86322000000
10	F1	Overload relay*	8~12.5A	YE01812500000
11	F2	Overload relay*	1~1.6A	YE01011600000
12	T	Transformer*	400V/230V 300mA	YE70402300700
13	FU1	Fuse**	2P	YE41032200000
14	-	Fuse core	1A	YE46001000100
15	FU2	Fuse**	2A	YE41001000000
16	X1	Terminal board	32A	YE61250040000
17	-	-	-	YE61253500000
18	-	Terminal board	32A	YE61250040000
19	-	-	-	YE61253500000
20	-	Terminal board	32A	YE61250040000
21	X2	Terminal board	32A	YE61250040000
22	H2	Indicate lamp	220VA	YE83305100200
23	X10	Metal tie in	4P	YE68025400000
24	-	-	4P	YE68025400100
25	S1	Emergency stop button	400VAC	YE11320300000
26	-	Contact block	1NC	YE19340000100
27	S2	Stop button	400VAC	YE11375800000
28	S3 H1	Start button	400VAC	YE11325300000
29	-	Contact block	1NO	YE19340000000
30	S4	Safety switch	AZ-17	-
31	H3	Buzzer	220VAC	YE84222000000
32	MS	Feed position motor	3A/25V	YE15000200100
33	M1	Granulating motor	400V 50/60Hz 4.0kW	-
34	M2	Solution blower	400V 50/60Hz 0.37kW	-

2.4.5 Electrical Circuit (230V)

Table 2-24: Electrical Circuit (230V)

SYMBOL MODE	(a)	(b)	(c)	(d)	(e)	(f)	(g)	(h)	(i)	(j)	(k)	(l)	(m)	(n)	(o)
SG-1621N	8.2	2.5	16	20	5.0-8.0	7.6	1.5	1.5	6.9	5	1.25-2.0	1.8	2.5	0.37	1.6
SG-1628NS	8.2	2.5	16	20	5.0-8.0	7.6	1.5	1.5	6.9	5	1.25-2.0	1.8	2.5	0.37	1.6
SG-1628N	10.5	2.5	16	25	8.0-12.5	9.9	2.5	2.2	9.1	5	1.25-2.0	1.8	2.5	0.37	1.6
SG-1635N	10.5	2.5	16	25	8.0-12.5	9.9	2.5	2.2	9.1	5	1.25-2.0	1.8	2.5	0.37	1.6
SG-2028N	10.5	2.5	16	25	8.0-12.5	9.9	2.5	2.2	9.1	5	1.25-2.0	1.8	2.5	0.37	1.6
SG-1635NH	13.8	2.5	25	32	10.0-16.0	14	2.5	3.0	12.5	5	1.25-2.0	1.8	2.5	0.37	1.6
SG-2028NH	13.8	2.5	25	32	10.0-16.0	14	2.5	3.0	12.5	5	1.25-2.0	1.8	2.5	0.37	1.6
SG-2042N	13.8	2.5	25	32	10.0-16.0	14	2.5	3.0	12.5	5	1.25-2.0	1.8	2.5	0.37	1.6
SG-2042NH	17.7	4.0	32	40	12.5-20.0	17	4.0	4.0	16.0	5	1.25-2.0	1.8	2.5	0.37	1.6

- (a) Main current (b) Main power cable dia. (c) Main rating current
 (d) Grinding motor circuit breaker (e) Grinding motor overload relay
 (f) Grinding motor overload relay setting value (g) Grinding motor cable dia.
 (h) Grinding motor power (i) Grinding motor current (j) Grinding motor circuit breaker
 (k) Conveying blower overload relay (l) Conveying blower overload relay setting value
 (m) Conveying motor cable Dia. (n) Conveying blower power (o) Conveying blower current

2.4.6 Main Circuit (230V)

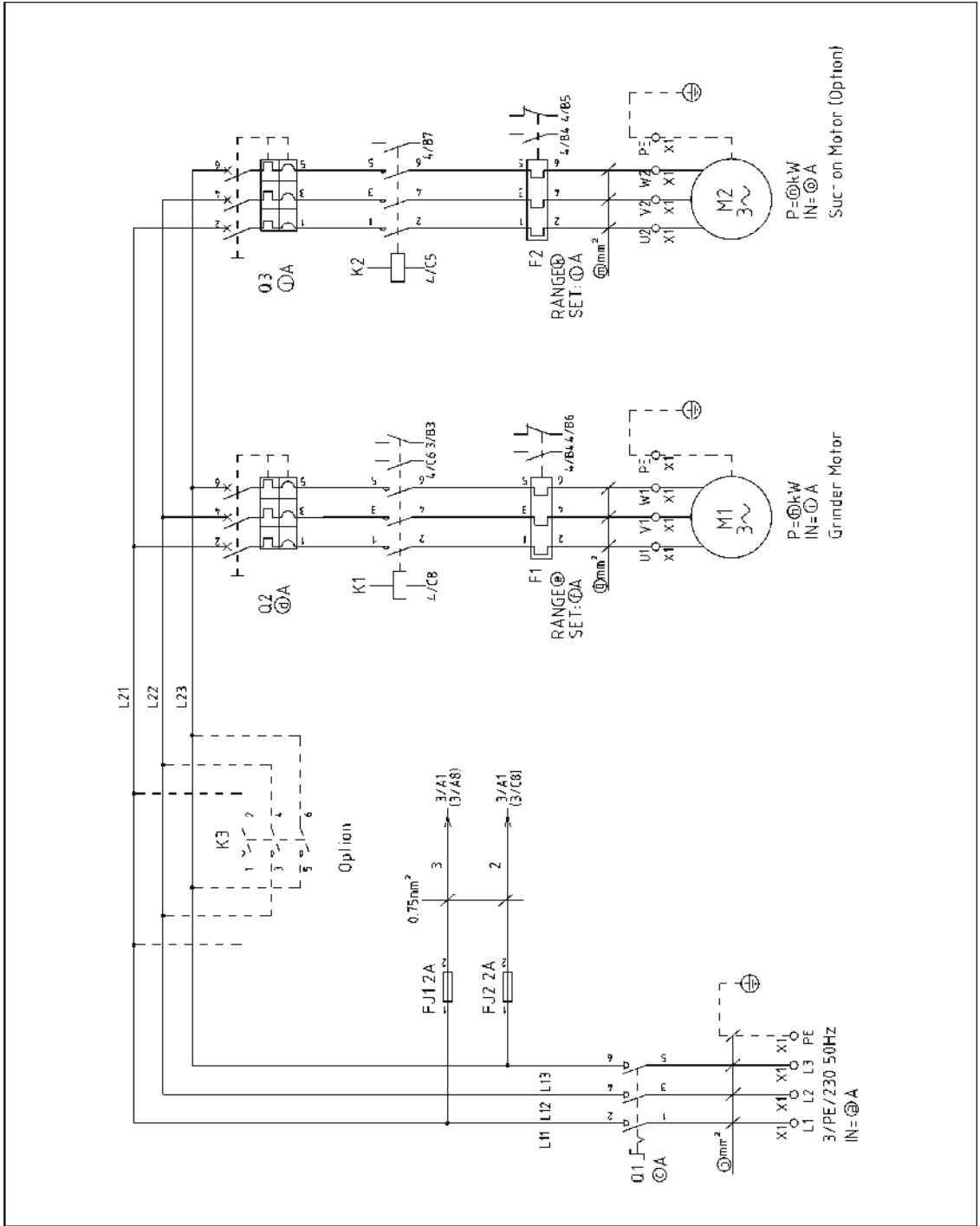

Picture 2-22: Main Circuit 1(230V)

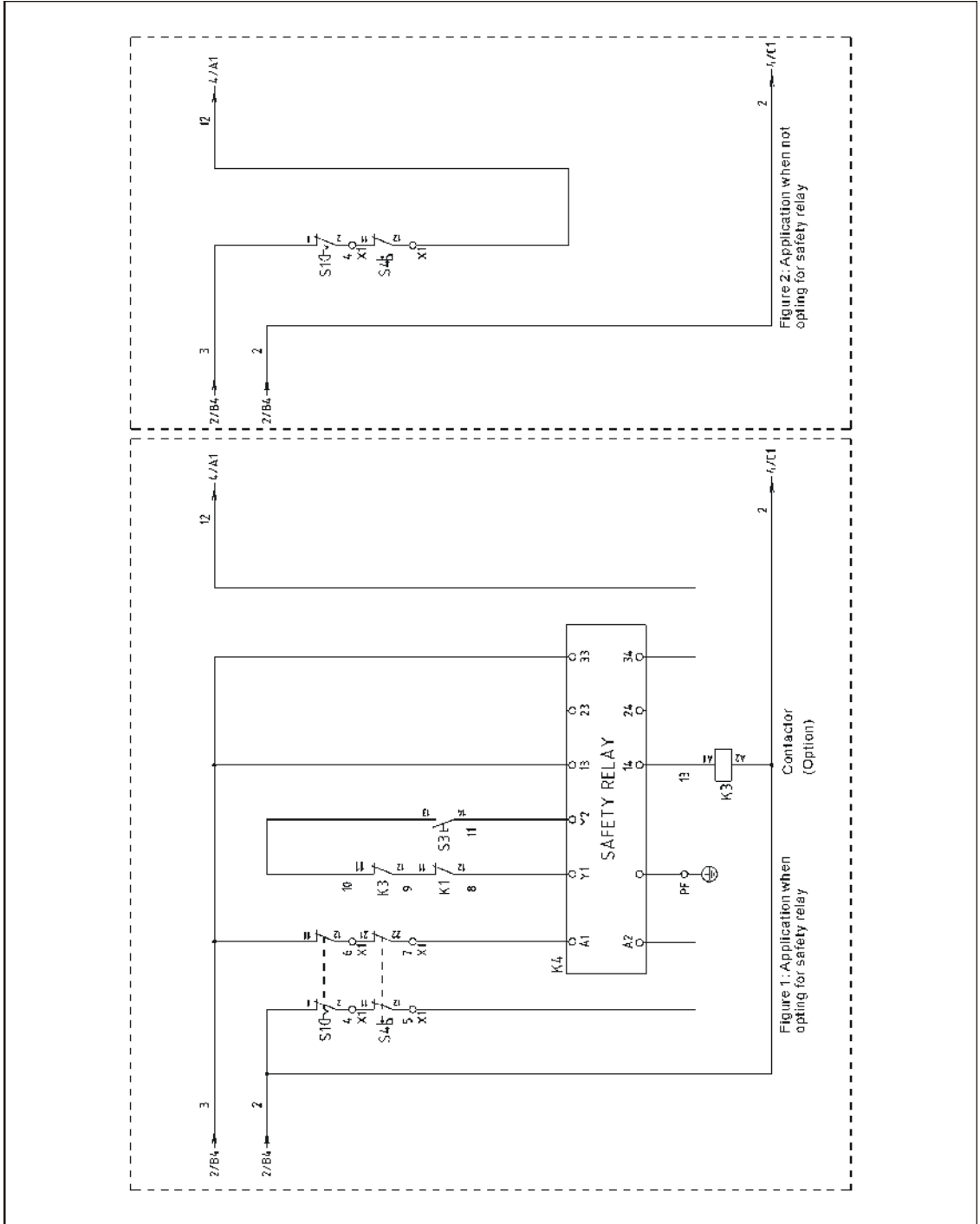

Picture 2-23: Main Circuit 2(230V)

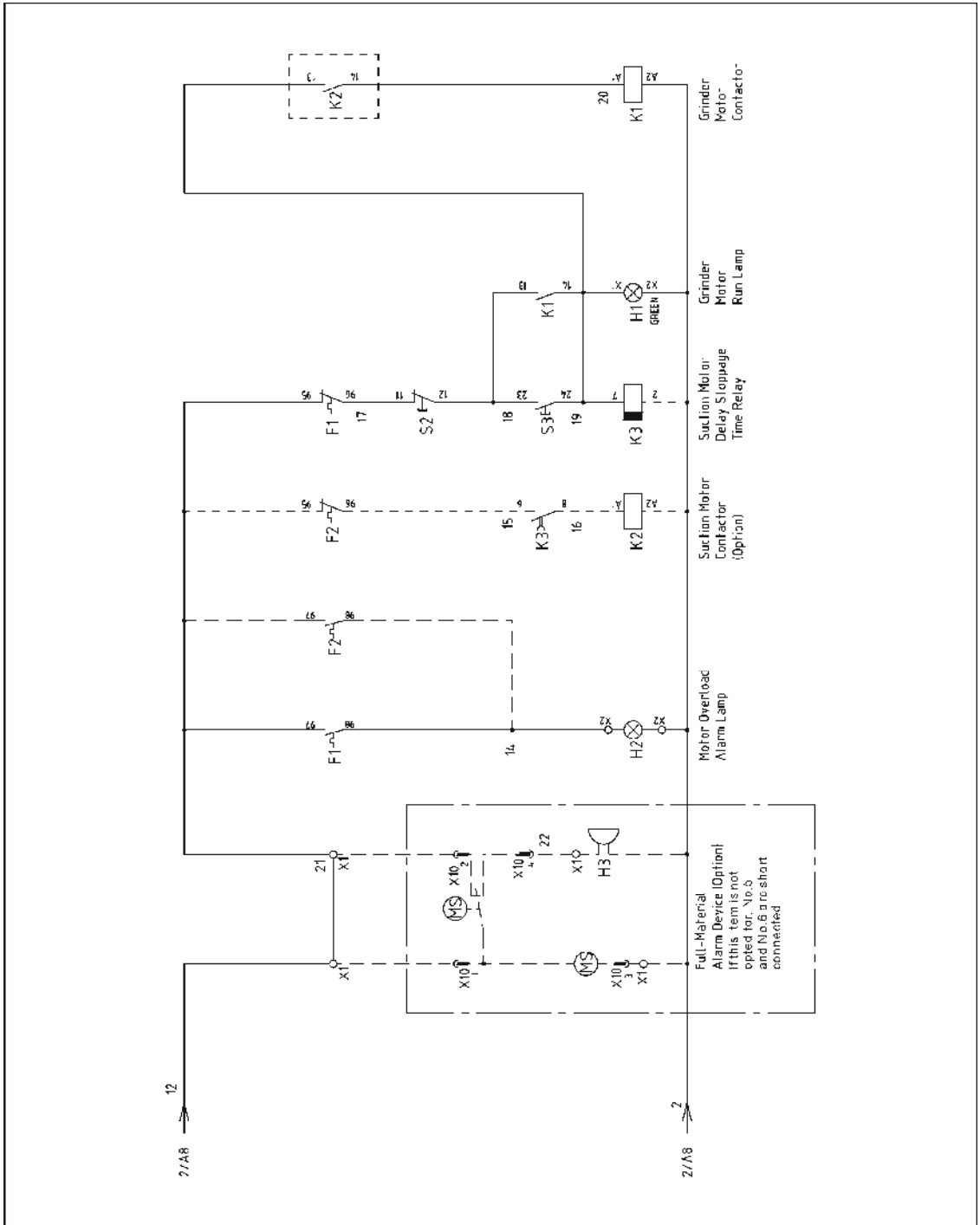

Picture 2-24: Main Circuit 3(230V)

2.4.7 Components Layout (230V)

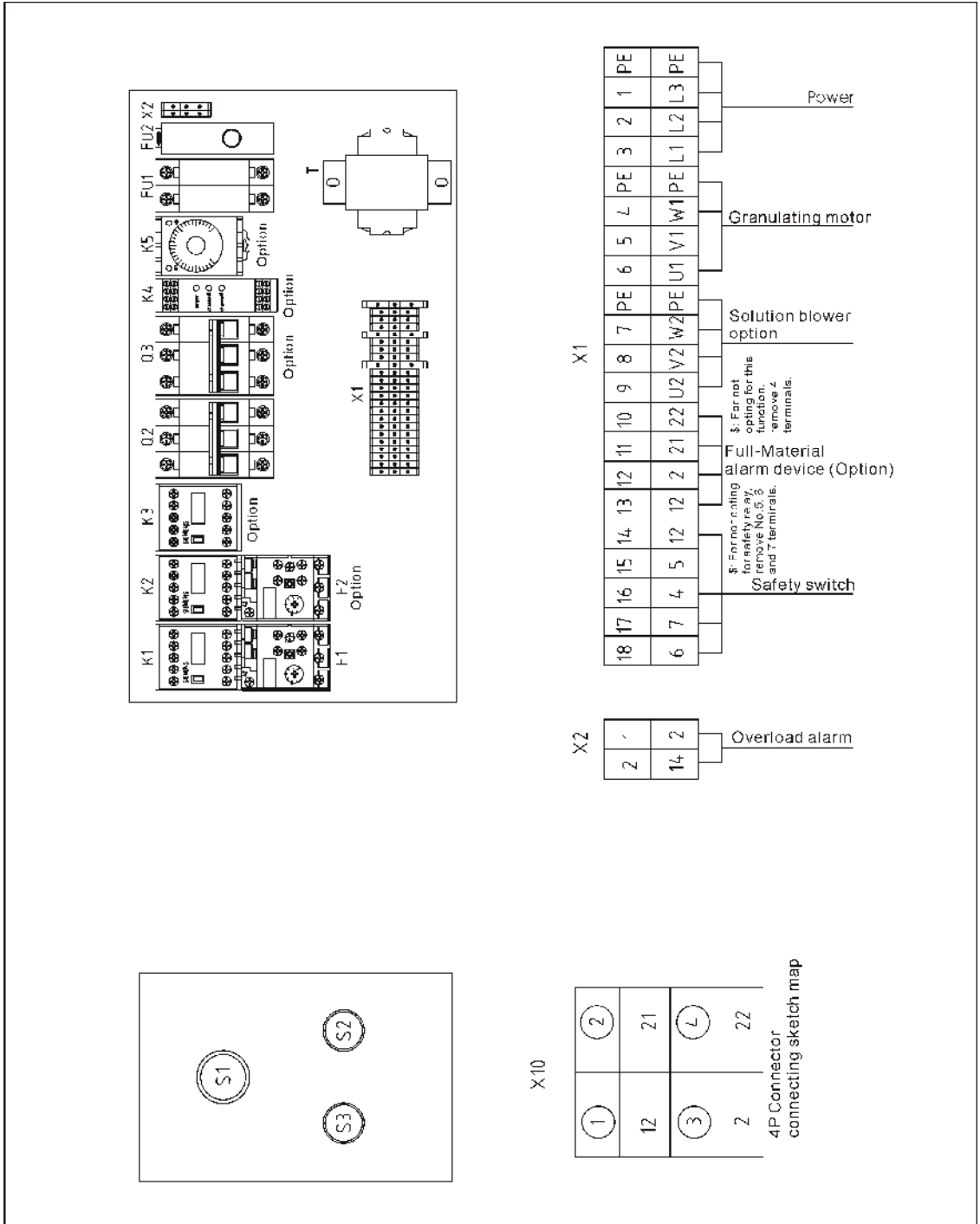

Picture 2-25: Components Layout (230V)

2.4.8 Electrical Components List (230V)

Table 2-25: Electrical Components List of SG-1621N (230V)

NO.	Symbol	Name	Specification	Part NO.
1	Q1	Main switch	16A	YE10021160000
2	Q2	Circuit breaker*	20A	YE40602000000
3	Q3	Circuit breaker*	5A	YE40603000000
4	K1	Contacto* ^r	230V 50/60Hz	YE00311000000
5	-	Auxiliary contact terminal	1NC	YE00400100200
6	K2	Contacto* ^r	230V 50/60Hz	YE00311000000
7	K3	Contacto* ^r	230V 50/60Hz	YE00310100000
8	K4	Safety relay	230VAC	YE04372100000
9	K5	Time relay	230VAC	YE86322000000
10	F1	Overload relay*	5~8A	YE01050800000
11	F2	Overload relay*	1.25~2A	YE01125200000
12	FU1 FU2	Fuse**	2A	YE41001000000
13	X1	Terminal board	32A	YE61250040000
14	-	-	-	YE61253500000
15	-	Terminal board	32A	YE61250040000
16	-	-	-	YE61253500000
17	-	Terminal board	32A	YE61250040000
18	X2	Terminal board	32A	YE61250040000
19	H2	Indicate lamp	220VA	YE83305100200
20	X10	Metal tie in	4P	YE68025400000
21	-	-	4P	YE68025400100
22	S1	Emergency stop button	400VAC	YE11320300000
23	-	Contact block	1NC	YE19340000100
24	S2	Stop button	400VAC	YE11375800000
25	S3 H1	Start button	400VAC	YE11325300000
26	-	Contact block	1NO	YE19340000000
27	S4	Safety switch	AZ-17	-
28	H3	Buzzer	220VAC	YE84222000000
29	MS	Feed position motor	3A/25V	YE15000200100
30	M1	Granulating motor	400V 50/60Hz 1.5kW	-
31	M2	Solution blower	400V 50/60Hz 0.37kW	-

* means possible broken parts.

** means easy broken part. and spare backup is suggested.

Please confirm the version of manual before placing the purchase order to guarantee that the item number of the spare part is in accordance with the real object.

Table 2-26: Electrical Components List of SG-1628N/1635N/2028N (230V)

NO.	Symbol	Name	Specification	Part NO.
1	Q1	Main switch	16A	YE10021160000
2	Q2	Circuit breaker*	22A	YE40602500000
3	Q3	Circuit breaker*	5A	YE40603000000
4	K1	Contacto* ^r	230V 50/60Hz	YE00311000000
5	-	Auxiliary contact terminal	1NC	YE00400100200
6	K2	Contacto* ^r	230V 50/60Hz	YE00311000000
7	K3	Contacto* ^r	230V 50/60Hz	YE00310100000
8	K4	Safety relay	230VAC	YE04372100000
9	K5	Time relay	230VAC	YE86322000000
10	F1	Overload relay*	8~12.5A	YE01812500000
11	F2	Overload relay*	1.25~2A	YE01125200000
12	FU1 FU2	Fuse**	2A	YE41001000000
13	X1	Terminal board	32A	YE61250040000
14	-	-	-	YE61253500000
15	-	Terminal board	32A	YE61250040000
16	-	-	-	YE61253500000
17	-	Terminal board	32A	YE61250040000
18	X2	Terminal board	32A	YE61250040000
19	H2	Indicate lamp	220VA	YE83305100200
20	X10	Metal tie in	4P	YE68025400000
21	-	-	4P	YE68025400100
22	S1	Emergency stop button	400VAC	YE11320300000
23	-	Contact block	1NC	YE19340000100
24	S2	Stop button	400VAC	YE11375800000
25	S3 H1	Start button	400VAC	YE11325300000
26	-	Contact block	1NO	YE19340000000
27	S4	Safety switch	AZ-17	-
28	H3	Buzzer	220VAC	YE84222000000
29	MS	Feed position motor	3A/25V	YE15000200100
30	M1	Granulating motor	400V 50/60Hz 2.2kW	-
31	M2	Solution blower	400V 50/60Hz 0.37kW	-

* means possible broken parts.

** means easy broken part. and spare backup is suggested.

Please confirm the version of manual before placing the purchase order to guarantee that the item number of the spare part is in accordance with the real object.

Table 2-27: Electrical Components List of SG-1635NH/2028NH/2042N (230V)

NO.	Symbol	Name	Specification	Part NO.
1	Q1	Main switch	25A	YE10125250000
2	Q2	Circuit breaker*	32A	YE40603200000
3	Q3	Circuit breaker*	5A	YE40603000000
4	K1	Contacto* [*]	230V 50/60Hz	YE00321100000
5	-	Auxiliary contact terminal	1NC	YE00400100200
6	K2	Contacto* [*]	230V 50/60Hz	YE00311000000
7	K3	Contacto* [*]	230V 50/60Hz	YE00321100000
8	K4	Safety relay	230VAC	YE04372100000
9	K5	Time relay	230VAC	YE86322000000
10	F1	Overload relay* [*]	10~16A	YE01101600100
11	F2	Overload relay* [*]	1.25~2A	YE01125200000
12	FU1 FU2	Fuse**	2A	YE41001000000
13	X1	Terminal board	32A	YE61250040000
14	-	-	-	YE61253500000
15	-	Terminal board	32A	YE61250040000
16	-	-	-	YE61253500000
17	-	Terminal board	32A	YE61250040000
18	X2	Terminal board	32A	YE61250040000
19	H2	Indicate lamp	220VA	YE83305100200
20	X10	Metal tie in	4P	YE68025400000
21	-	-	4P	YE68025400100
22	S1	Emergency stop button	400VAC	YE11320300000
23	-	Contact block	1NC	YE19340000100
24	S2	Stop button	400VAC	YE11375800000
25	S3 H1	Start button	400VAC	YE11325300000
26	-	Contact block	1NO	YE19340000000
27	S4	Safety switch	AZ-17	-
28	H3	Buzzer	220VAC	YE84222000000
29	MS	Feed position motor	3A/25V	YE15000200100
30	M1	Granulating motor	400V 50/60Hz 3.0kW	-
31	M2	Solution blower	400V 50/60Hz 0.37kW	-

* means possible broken parts.

** means easy broken part. and spare backup is suggested.

Please confirm the version of manual before placing the purchase order to guarantee that the item number of the spare part is in accordance with the real object.

Table 2-28: Electrical Components List of SG-2042NH (230V)

NO.	Symbol	Name	Specification	Part NO.
1	Q1	Main switch	32A	YE10323200000
2	Q2	Circuit breaker*	40A	YE40604000000
3	Q3	Circuit breaker*	5A	YE40603000000
4	K1	Contactoer*	230V 50/60Hz	YE00321100000
5	-	Auxiliary contact terminal	1NC	YE00400100200
6	K2	Contactoer*	230V 50/60Hz	YE00311000000
7	K3	Contactoer*	230V 50/60Hz	YE00331100000
8	K4	Safety relay	230VAC	YE04372100000
9	K5	Time relay	230VAC	YE86322000000
10	F1	Overload relay*	12.5~20A	YE01125200100
11	F2	Overload relay*	1.25~2A	YE01125200000
12	FU1 FU2	Fuse**	2A	YE41001000000
13	X1	Terminal board	32A	YE61250040000
14	-	-	-	YE61253500000
15	-	Terminal board	32A	YE61250040000
16	-	-	-	YE61253500000
17	-	Terminal board	32A	YE61250040000
18	X2	Terminal board	32A	YE61250040000
19	H2	Indicate lamp	220VA	YE83305100200
20	X10	Metal tie in	4P	YE68025400000
21	-	-	4P	YE68025400100
22	S1	Emergency stop button	400VAC	YE11320300000
23	-	Contact block	1NC	YE19340000100
24	S2	Stop button	400VAC	YE11375800000
25	S3 H1	Start button	400VAC	YE11325300000
26	-	Contact block	1NO	YE19340000000
27	S4	Safety switch	AZ-17	-
28	H3	Buzzer	220VAC	YE84222000000
29	MS	Feed position motor	3A/25V	YE15000200100
30	M1	Granulating motor	400V 50/60Hz 4.0kW	-
31	M2	Solution blower	400V 50/60Hz 0.37kW	-

* means possible broken parts.

** means easy broken part. and spare backup is suggested.

Please confirm the version of manual before placing the purchase order to guarantee that the item number of the spare part is in accordance with the real object.

2.5 Electrical Components Description

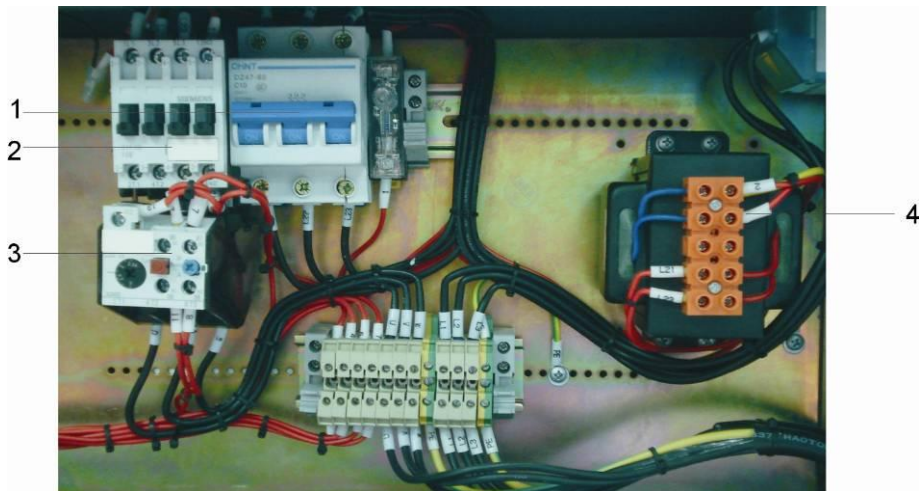

Picture 2-26: Electrical Components Description

1. Circuit breaker, which performs the function of short circuit protection or circuit isolation.
2. Electromagnetic switch, which can connect or disconnect the power from remote.
3. Thermo overload relay, which can protect the motor when they are overloading or phase opening.
4. Transformer, which can provide suitable voltage for the control circuit.

2.6 Optional Accessories

2.6.1 Screen

There are $\Phi 4.0$, $\Phi 5.0$, $\Phi 6.0$, $\Phi 8.0$, $\Phi 10$, $\Phi 12$ mm for screen dia. , of which standard SG-16 adopts $\Phi 5.0$ (mm), and SG-20 adopts $\Phi 6.0$ mm.



Picture 2-27: Screen

2.6.2 Blade Selection

Material SKD-11 is applicable to cut general plastic, (standard equipment).

Material SKH9 is applicable to cut fiber added plastics.



Picture 2-28: SKD-11

2.6.3 30 Seconds Instant recycling system

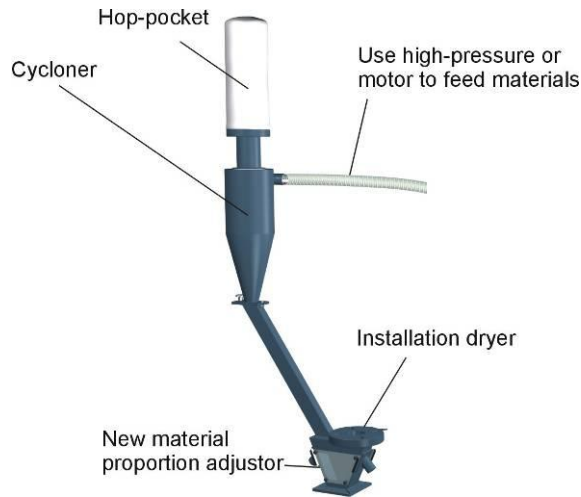

Picture 2-29: 30 Seconds Instant recycling system

This device utilizes high pressure air or loading blower to easily convey the regrind material within storage box to "new and regrind material proportion governor" to get mixed and recycled, so to keep it from quality and color changing by oxidation or dampng.

- 1) Align flange base to the hole of 30 seconds instant recycling system and use M8×35 screw to fix it.



Picture 2-30: 30 Seconds Instant Recycling System 1

2) Fix the bend and the cyclone dust collector with M5×15 screw and pay special attention to the direction of the bend, it can not be at the same side with the air inlet of the cyclone dust collector.



Picture 2-31: 30 Seconds Instant Recycling System 2

3) Fix the cyclone dust collector and the 30 seconds instant recycling system with M8 screw nuts and lockup screws.



Picture 2-32: 30 Seconds Instant Recycling System 3

4) Install cloth bag at the bend place and lock it up.



Picture 2-33: 30 Seconds Instant Recycling System 4

5) Use steel wired hose to connect the outlet of loading blower to the inlet of the cyclone dust collector.



Picture 2-34: 30 Seconds Instant Recycling System 5

6) Mount drying machine at the flange base of the 30 seconds instant recycling system.

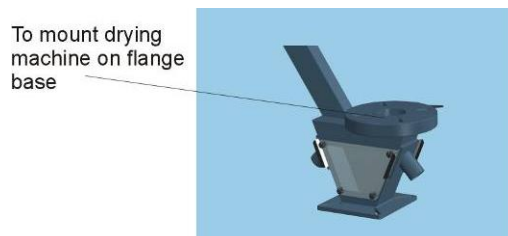

Picture 2-35: 30 Seconds Instant Recycling System 6

Option 1: 30 secs instant recycling system model: A (loading with high pressure air).



Picture 2-36: Loading With High Pressure Air

Option 2: 30 secs instant recycling system model: A (loading with blower).



Picture 2-37: Loading With Blower

Option 3: Blower +cyclonic loading device

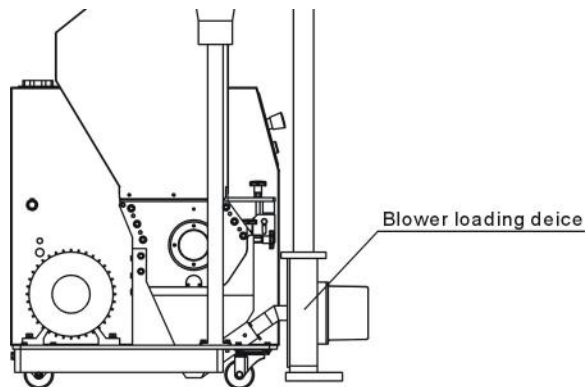

Picture 2-38: Option 3: Blower + Cyclonic Loading Device

2.6.4 Proportional Valve



Picture 2-39: Control Box



Picture 2-40: Valve Body

Option 4: Dust separating system

Dust separating system can separate dust within the granule, then store the granule for recycle use. The regrind material drop into dust separating system after conveyed to cyclone dust collector. There, pass by screen separator, the dust is sucked into the dust collecting bag while granule is conveyed back to the "new and regrind material proportion governor" for recycle use. This will prevent sprue material from turning black spot, the dia.

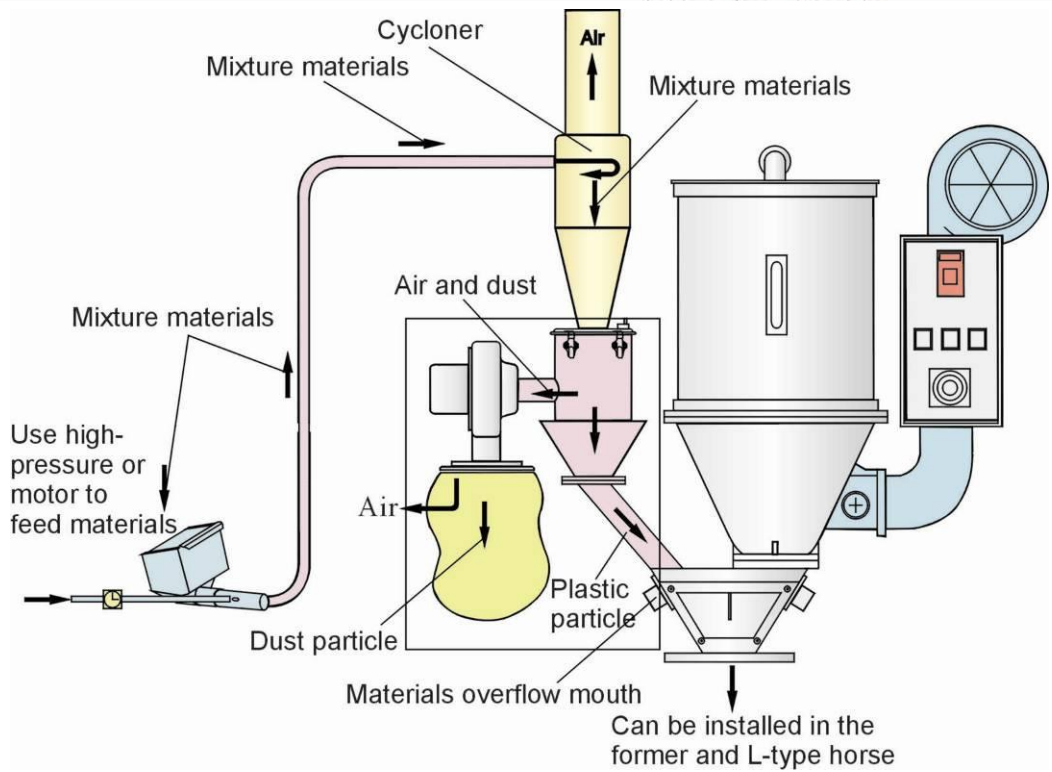
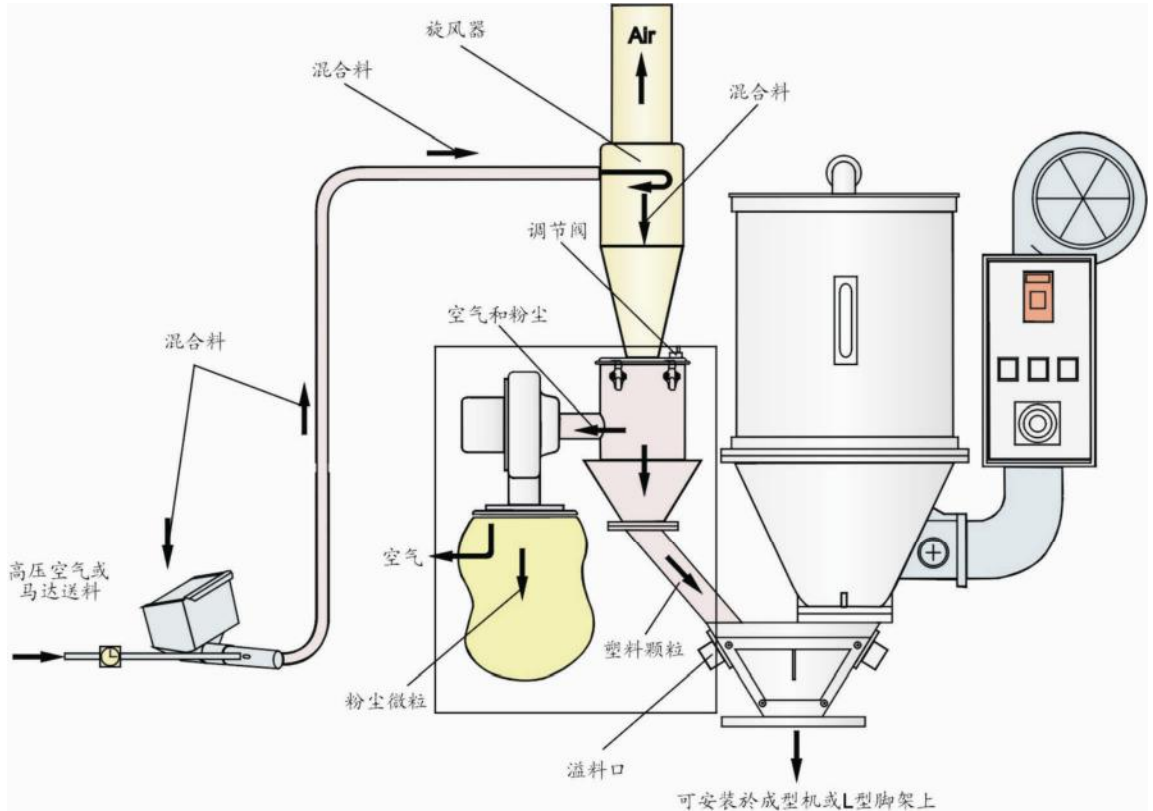

Picture 2-41: Dust separating System

Option 5: Coiled spring conveyor

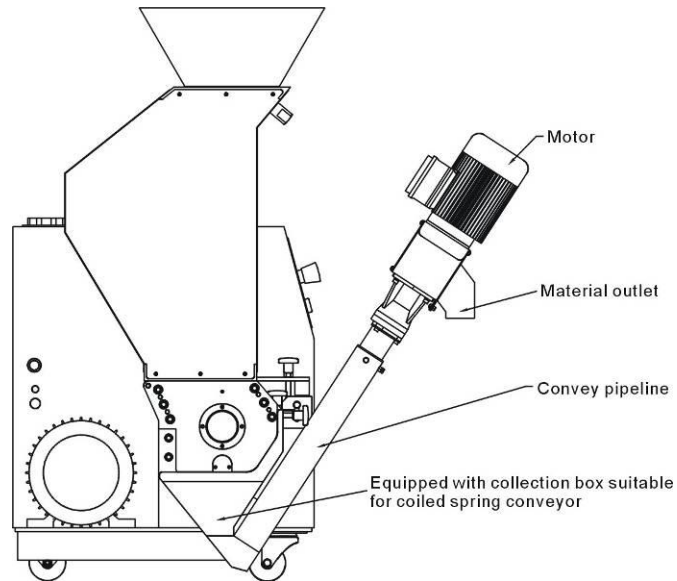

Coiled spring conveyor drives the cylindrical coiled spring to rotate through a motor and conveys the regrinds in the collection box to the discharge port. It is more convenient for users can collect the regrinds from the discharge port automatically by putting a container under the discharge port rather than detaching the collecting from the granulator.

3. Installation and Debugging



Read this chapter carefully before installation.



Install as following orders to avoid any accident!



Be careful! Not to be cut by the sharp blade.



Power connection must be done by the professional electrician to avoid electrical shock.



Caution!

Cutters should be laid level, prevent the cutters from self-rotating when do installation, don't let your hands be near to the cutters to avoid personal injury.



Notice!

Do not install the cutters by working together, because this could bring personal injury. Use a thick wood block to stop the rotating knives from turning.



Notice!

The blades are very sharp, so use protective gloves to avoid being cut.



Notice!

Please use new screws and gaskets when installing cutters.

3.1 Installation Notice

- 1) Make sure voltage and frequency of the power source comply with those indicated on the manufacture's plate, which is attached to the machine.
- 2) Power cable and earth connections should conform with local regulations.
- 3) Use independent power cable and ON/OFF switch. The cable's dia. Should not smaller than those applied in the control box.
- 4) The power cable connection terminals should be tightened securely.
- 5) The machine requires a 3-phase 4-wire power source, connect the power lead (L1, L2, L3) to the live wires, and the earth (PE) to the ground.
- 6) Power supply requirements:
 Main power voltage: $\pm 10\%$
 Main power frequency: $\pm 2\%$

Make at least 1 meter clearance around the machine to facilitate repair and maintenance.



Picture 3-1: Installation Space

Table 3-1: Attached Form, Cutters and Other Fixing Screw Torque

Thread size	M10	M12	M14	M16	M18	M20	M22	M24
Axial force (N)	23.8	34.5	47	65.5	78.5	103	129	149
Fixing torque (Nm)	50	86	135	215	290	420	570	730

3.2 Installation Place



Make enough installation space to help the repair and maintenance.

Check and make sure the installation ground is level, there is enough intensity when it is running.

Lockup the castors to prevent the granulator from moving.

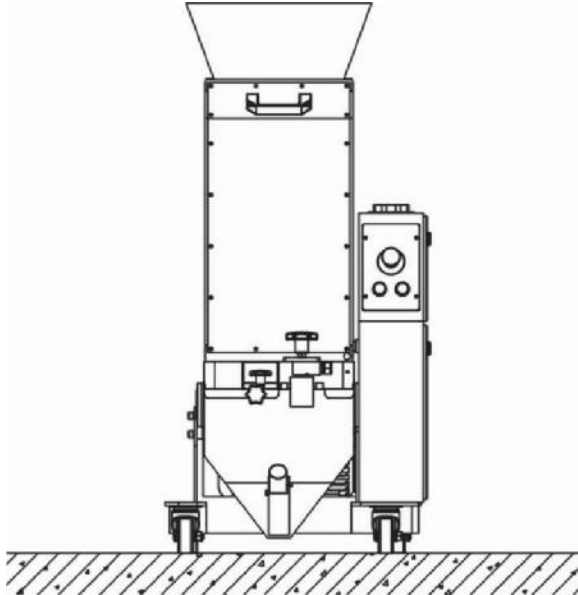

Picture 3-2: Installation Place

3.3 Installation of Bearing and Blade Rest

- 1) Put oil seal (see figure 2) and bearing (see figure 1) orderly into bearing pedestal. (See figure 3).



Picture 3-3: Installation of Bearing and Blade Rest 1

- 2) Insert blade shaft (see figure 2) vertically into blade rest (see figure 3), let

hydraulic machine (see figure 1) compress it tightly.

- 3) Mount shaft sleeve (see figure 4) and material flap (see figure 5) orderly into the main shaft (see figure 2) and to make the material flap completely match shaft sleeve and blade rest.
- 4) Mount bearing pedestal (see figure 4) onto the blade rest and use hydraulic machine to press tight. (see figure 3)

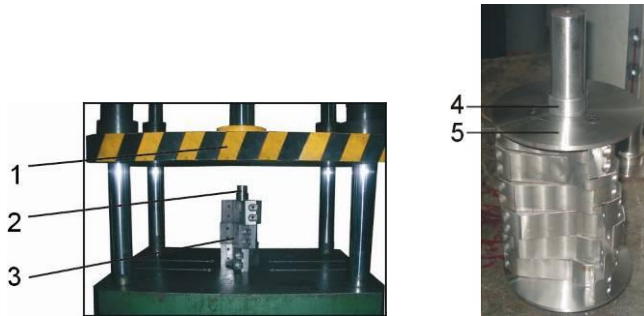

Picture 3-4: Installation of Bearing and Blade Rest 2

- 5) Put the installed blade rest (see figure 1) into the cutting chamber (see figure 2).



Picture 3-5: Installation of Bearing and Blade Rest 3

- 6) Install the bearing cover and tighten it by screw. (See figure 1).



Picture 3-6: Installation of Bearing and Blade Rest 4



Note!

Apply grease on the bearing and bearing pedestal.

3.4 Installation of Rotating Blade and fixed Blade



Note!

The blade is very sharp edged, so wear gloves before installation and care shall be taken when installation to avoid injury!

Installation steps:

- 1) Put the rotating blades, and their pressing blocks orderly to the installation position on the rotating blade retainer.

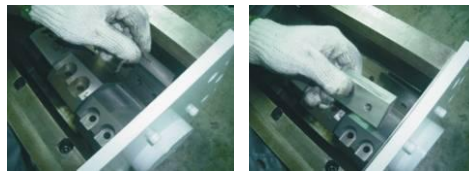

Picture 3-7: Installation of Rotating Blade and fixed Blade 1

- 2) Lock the screws corresponding to blades with proper torque. (Torque: 43Nm)



Picture 3-8: Installation of Rotating Blade and fixed Blade 2

- 3) Put the pressing blocks onto the fixed blades, align screws to the fixing holes and lock them tightly.



Picture 3-9: Installation of Rotating Blade and fixed Blade 3

- 4) Use proper small wrench to adjust the distance of fixed blades and rotating blades to 0.2~0.3mm (Picture 5.4-5) and lock the fixed blade tightly.



Picture 3-10: Installation of Rotating Blade and fixed Blade 4



Note!

To avoid bodily injury and machine damage, the fixing screw of blades shall be tightened well.

When adjusting the clearance, it shall not be too small to avoid damage to the cutter!

3.5 Installation of Belt and Belt Pulley

- 1) Install one end of the main shaft into the guide hole of the blade shaft, then tighten the screw with correct torque (84Nm) after matching the hole on the housing case, by this way to fix the right bearing block on the housing case.



Picture 3-11: Installation of Belt and Belt Pulley 1

- 2) Set taper sleeve into big belt pulley first before putting the big belt pulley on main shaft



Picture 3-12: Installation of Belt and Belt Pulley 2

- 3) Fit big belt pulley and taper sleeve right on main shaft.



Picture 3-13: Installation of Belt and Belt Pulley 3

- 4) Tighten up the two screws on taper sleeve (torque value is 90Nm). Before tightening, the needle of dial indicator contacts the edge of belt pulley. As the pulley is turned, tighten the lock screw as indicated by the dial indicator (its range is 0.01-0.03mm) to enable the lock rings are fully engaged between the pulley and the blade shaft.



Picture 3-14: Installation of Belt and Belt Pulley 4

- 5) Put the small belt pulley on the motor to allow the key of motor corresponding with the key groove on the belt pulley. Then tighten the two screws on the taper sleeve (torque value is 20Nm).



Picture 3-15: Installation of Belt and Belt Pulley 5

- 6) Put the belt on the blade shaft belt pulley and motor belt pulley. The tooth of belt shall correspond with synchronal gear. Turn the blade shaft and motor shaft to enable the tooth of belt fully corresponds with the pulley tooth under totally even stress.



Picture 3-16: Installation of Belt and Belt Pulley 6



Note!

Apply grease on the bearing and bearing pedestal. Apply applicable torque to tighten the key and the screw on the shaft.

- 7) Put the straight edge closely against the surface of the blade shaft belt pulley; then observe the spacing between two pulleys and the straight edge and adjust the motor belt pulley at the same time to allow the surface of the motor belt pulley parallel with it.



Picture 3-17: Installation of Belt and Belt Pulley 7

- 8) Adjust the adjusting screws at both ends of motor fixed plate by the wrench until two belt pulleys are parallel, to keep the motor flat and the belt tensioned. Use the correct torque (84Nm) until the pulley moves to the place where the belt is balanced.



Picture 3-18: Installation of Belt and Belt Pulley 8

- 9) Tighten the fix screws of motor at four corners to allow the motor fixed on the base plate of granulator.



Picture 3-19: Installation of Belt and Belt Pulley 9



Be careful!

The cutting blade rest shall be put stably. Self turning of cutting tool shall be prevented prior to installation. At the time of operating, hand shall stay away from the cutting tool to avoid bodily injury.

3.6 Installation of Feed Box and Feed Port

- 1) Lift up the feed box (figure 1) to fix it onto the cutting chamber. Clean up impurities on the contacting interface, thus use fixing rod (figure 2) to fix it onto the cutting chamber.

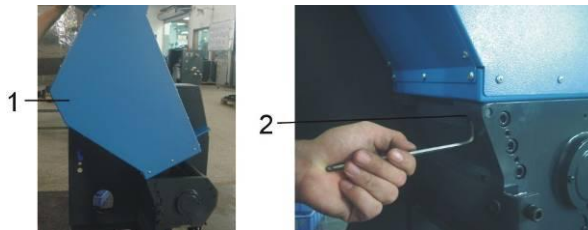

Picture 3-20: Installation of Feed Box and Feed Port 1

- 2) Hold the feed port (figure 3), and insert it into the feed box.



Picture 3-21: Installation of Feed Box and Feed Port 2



Attention!

Lock each screw with right torque (5.9Nm).

3.7 Installation of Screen and Screen Frame

- 1) Put screen (1) on to the screen frame (2) and make its notch tallies with collar on the screen frame.



Picture 3-22: Installation of Screen and Screen Frame 1

- 2) Hold the screen frame with hands and make stationary axis on both ends fit to the grooves and then push the frame inside (see the direction arrow shows).

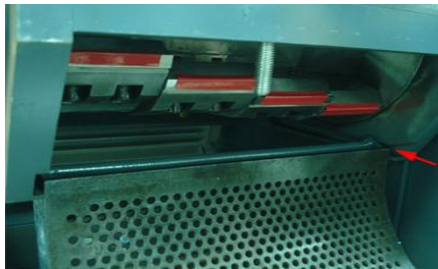

Picture 3-23: Installation of Screen Frame 1

- 3) Hold the screen frame and move it along the groove as the direction arrow shows until the stationary axis reach the groove end.



Picture 3-24: Installation of Screen Frame 2

- 4) Uplift the front end of the screen frame; lock the screen tightly with a star knob.

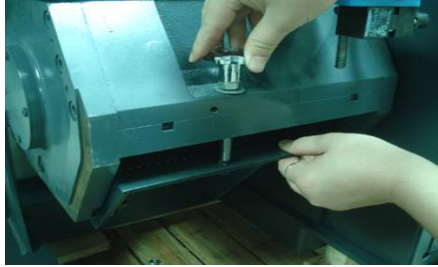

Picture 3-25: Installation of Screen Frame 3

3.8 Installation of Material Collection Box.

- 1) Move the material collection box to the direction arrow showed in the picture below.



Picture 3-26: Installation of Material Collection Box 1

- 2) Move up the material collection box as the bold arrow showed, then pull back and make the edgefold (2) of the box hook up the edgefold (1) of the siding.

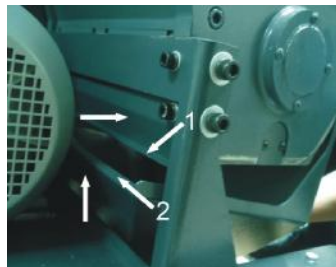

Picture 3-27: Installation of Material Collection Box 2

- 3) The after installation state of material collection box is showed in the picture below.



Picture 3-28: Installation of Material Collection Box 3

- 4) Fasten the star knob and finish the installation. See picture below.



Picture 3-29: Installation of Material Collection Box 4

4. Operation Guide



Wear earplugs during operating to avoid personal injury!



Wear gloves during operating to avoid personal injury!



Wear goggles during operating to avoid personal injury!



Because the blades and rotor may be loosen, check the following items before operating:

- 1) If the blades has any damage.
- 2) If the surface of the rotor is loosen.
- 3) Push or pull the rotor and blades to see if there is any loose connection.

If any of the above situations is found, please contact local representative or SHINI Company for help.

4.1 Startup Pretest

Unpainted part of the machine has been covered with stainless oil. Before use, the stainless oil should be cleaned.

- 1) Clean with a towel.
- 2) Wash with a towel dipping with amyl acetate.

4.1.1 Before the First Startup

- 1) Check whether the granulator is in the level state.
- 2) Check the space of the cutting tools to see whether the lockup screws of the blades are tightened (torque: 280Nm).

4.1.2 After First Startup for 2 Hours

- 1) Check the space of the cutting tools of the fixed blades and rotating blades again; check whether the lockup screws of the blades are loose.

- 2) Check the position-adjusting screws of the motor and check whether the position-adjusting screws are tightened.

4.1.3 After First Startup for 20~30 Hours

Check and adjust the belt's tensility after a 20~30-hour full-load operation.

4.2 Circuit Connection



CAUTION!

The installation of the granulator's circuit must be conducted by the professional electricians.

- 1) Connect granulator to the power.
- 2) Connect the transmission belt clockwise.

Check the Running Direction of the Motor

- 1) Open the door to check whether the feed box is closed.
- 2) Ensure the main power switch is in ON position.
- 3) Check the emergency stop.
- 4) Start the granulator via pressing the START button and stop the granulator via pressing the STOP button.
- 5) The granulator needs some time to fully come to a halt; After full stop, check whether the running direction is clockwise.



CAUTION!

The cutting tools may be damaged and the granulating capability will be reduced if there is a wrong running direction. Please disconnect the power and transpose any two wires of the three in the main power.

4.3 Open the Feed Box and Storage Box



Before opening the feed box and the storage box, turn off the main power switch and the power switch of the granulator.



Be careful! The blade is very sharp, please take care.

4.3.1 Open the Feed Box

- 1) Check if the feed box has been emptied. If so, turn off the main power switch.

2) Loosen the long star screw and open the feed box.



Picture 4-1: Open the Feed Box

4.3.2 Open the Storage Box

- 1) Shut off the power of granulator.
- 2) Remove the storage box.

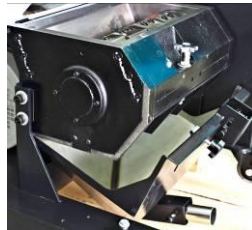

Picture 4-2: Open the Storage Box

4.3.3 Open the Screen and Screen Frame

- 1) Shut off the power of granulator.
- 2) Loose the long star screw and open the screen frame.



Picture 4-3: Open the Screen and Screen Frame 1

3) Take out screen and screen frame.



Picture 4-4: Open the Screen and Screen Frame 2

4.4 Shut Up the Feed Box and Storage Box

4.4.1 Close the Feed Box

- 1) Check to ensure there is no powder left in the interface or corners.
- 2) Close the feed box forwardly.
- 3) Lock up the star screw and fix the feed box.



Picture 4-5: Close the feed box

4.4.2 Shut up the Storage Box



Note!

Before closing, clean the interface surface.

Be careful!

Don't get squeezed and injured.

- 1) Check no powder or leftover material around the cutting chamber, screen and screen frame; timely remove them if any.
- 2) Mount the screen and lock its star screw tightly.
- 3) Mount the storage box and lock its star screw tightly.



Picture 4-6: Shut up the Screen and Screen Frame

4.5 Start and Stop the Granulator

The granulator is controlled by main power switch, safety switch, START / STOP button and emergency stop button.

Main power switch:

It is located at the front control panel. Through rotating the switch to control the startup and stop of the machine.



Picture 4-7: Main Power Switch

START button and STOP button:

These two buttons control the startup and stop of the machine.

Emergency Stop:

When an accident happens, this button can do a favor.

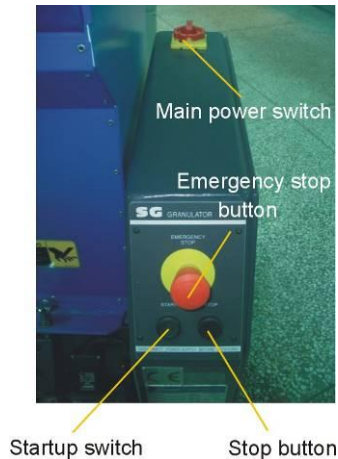

Picture 4-8: Stop, Emergency Stop and Startup button



CAUTION!

If there are ungrinded crew materials in the feed box or cutting chamber, the granulator shall NOT be stopped, otherwise the crew materials will blockade the rotor and the motor will be overloaded next time you start the machine up.

4.6 Blades Installation Adjusting (SG-20N)

All the cutters, including rotating blades and fixed knives, can be adjusted within clamp outside the machine.

Put all the cutters including rotating knives and fixed knives into clamp, adjusting its adjusting screw until the screw reach the clamp.

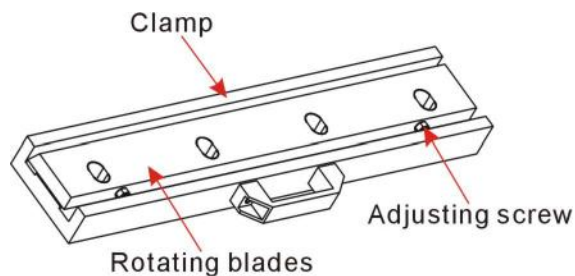

Picture 4-9: Blades Installation Adjusting (SG-20N)

5. Trouble-shooting

5.1 Granulator Can Not Work

- 1) Check if the emergency stop has not been reset. If not, rotate the Button anti-clockwise to reset it.
- 2) Check if the safe switch between feed box and storage box is completely closed. If not, machine can not be switched on.
- 3) Check the motor's overload protector.

The overload protector in the electrical control box will work if the motor overloads. Under that situation, (A) (the green pole) will sprout. Press the reset button (B) to reset it. Before startup again, check whether there is any powder in the granulator.

- 4) Check the overload protector of the feeding blower's motor.

If the feeding blower does not run, the granulator cannot run either. Check the motor protector in the electric control box. If it is closed, the switch will be in 0 positions. Reset it to 1 position. (A) (The green pole) will sprout. Press the reset button B) to reset it.

- 5) Check the space between blades

A stop will happen or the motor overload protector will work if the blade is very blunt or the space between blades is not correct. Protector will be shut if motor is overload. Blades should be checked, replaced or adjust the space between blades.

- 6) The contactor is burnt down or the control circuit is open.



5.2 Stop Due to Other Reasons

Connection failure or looseness of safety switch or limit switch can also result in

operation failure.



Note!

Do not disconnect to safety switch or control switch.

6. Maintenance and Repair

6.1 Repair

All the repair must be done by professionals to avoid damage to machine and harm to human body.

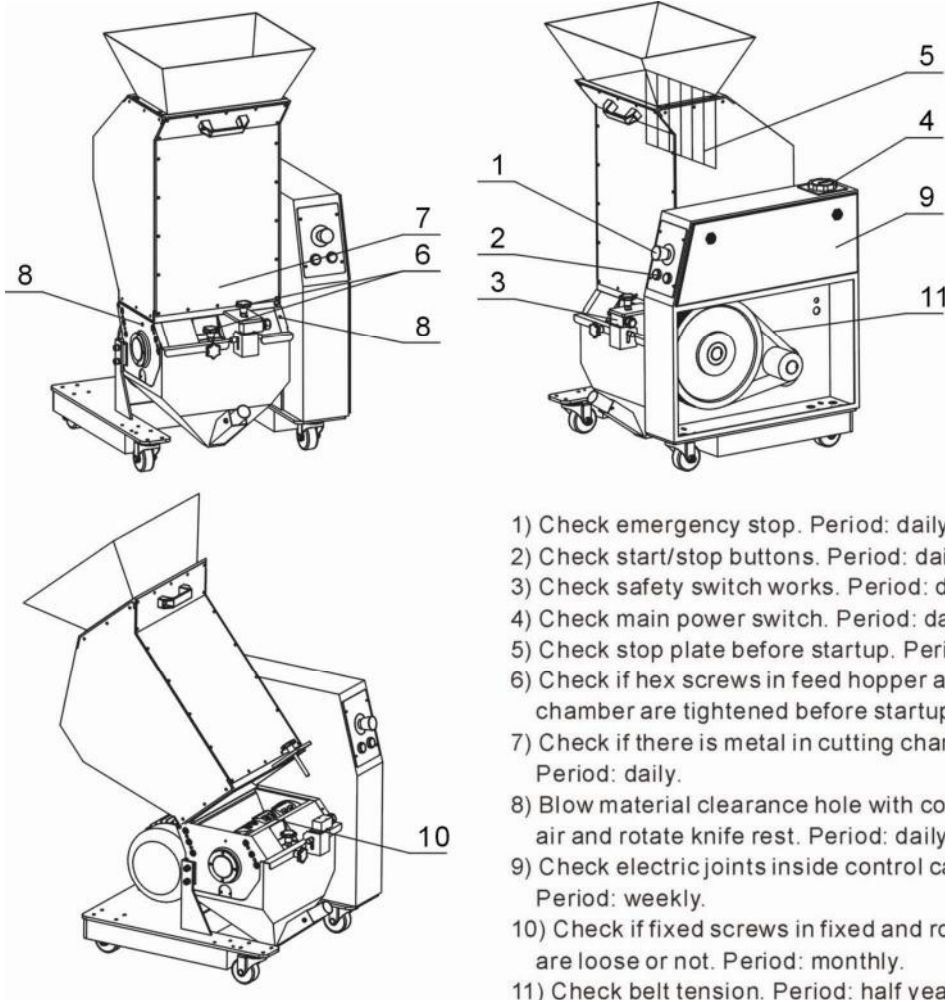

- 1) Check emergency stop. Period: daily.
- 2) Check start/stop buttons. Period: daily.
- 3) Check safety switch works. Period: daily.
- 4) Check main power switch. Period: daily.
- 5) Check stop plate before startup. Period: daily.
- 6) Check if hex screws in feed hopper and cutting chamber are tightened before startup. Period: daily.
- 7) Check if there is metal in cutting chamber. Period: daily.
- 8) Blow material clearance hole with compressed air and rotate knife rest. Period: daily.
- 9) Check electric joints inside control cabinet. Period: weekly.
- 10) Check if fixed screws in fixed and rotate blades are loose or not. Period: monthly.
- 11) Check belt tension. Period: half yearly.

6.1.1 Blades Structure in Cutting Chamber

SG-16N series adopt new type staggered blades and unfixed blades which can keep a settled cutting clearance without adjustment after resharpening. Below is the blades structure in cutting chamber:

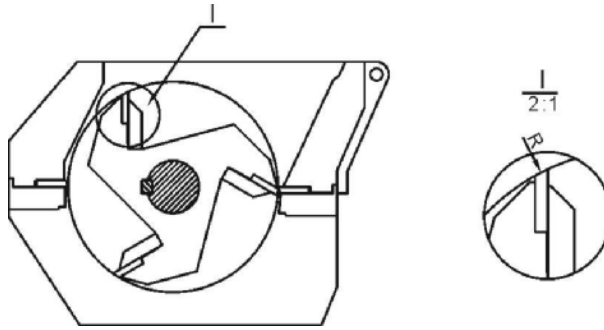

Picture 6-1: Blades Structure in Cutting Chamber

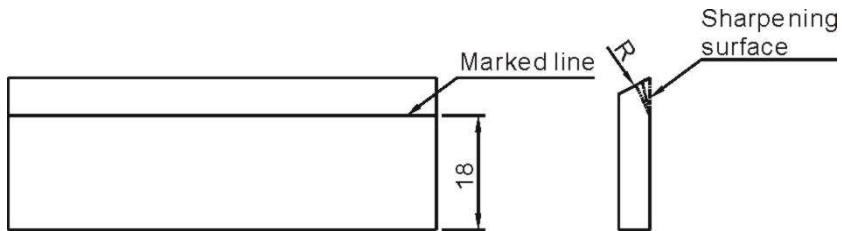

Picture 6-2: Rotate Blades Sharpening

6.1.2 Replace the Blades



CAUTION!

Warning: Self-rotation exists due to non-balanced forces or unstable barycenter.



Wear gloves to avoid being cut and be careful of the sharp blades!

More details about replacing or maintaining the blades to see chapter 3.4. Inject screw thread fixing glue (light blue LOCTITE 243 recommended) to the fixing screw so to avoid slipping and tighten screws up.



Press Emergency Stop and Switch main power when Replacing Blades!



Wear gloves to avoid being cut and be careful of the sharp blades!
More details about replacing or maintaining the blades to see chapter 3.4.
Inject screw thread fixing glue (light blue LOCTITE 243 recommended)
to the fixing screw so to avoid slipping and tighten screws up.



Picture 6-3: Maintain and Clean Blades



CAUTION! To decrease the possibility of harm to other people, the replacement action must be conducted by oneself.



To avoid self-rotation, block the rotating blades with a thick wood block.
Be careful with the sharp blades.



Each time to replace the blade, the screw and insulation ring must be replaced also.

Before replacing the blades, open the feed box, remove the storage box, screen and screen frame.

1) Remove the fixed blades



CAUTION!

To avoid self rotation, block the rotating blade with a thick wood block.

1) Remove the screws and insulation rings.

- 2) Remove the blades.
- 3) Clean the installation surface of the blades.

2) Remove the rotating blades

1. Loosen and remove the hexagon socket cap screw.
2. Clean the whole rotating blades and cutting chamber.



CAUTION!

Press the pressing block and blade when you remove the last screw.

3) Install the blades

Clean carefully the fixed blades and rotating blades and then install them.



CAUTION!

Each time to replace the blade, the screw and insulation ring must be replaced also.

Install the back fixed blades then the front fixed blades, finally the rotating blades. More details about replacing or maintaining the blades to see chapter 3.4.

4) Check the blades

Turn around the blade rest till all the blades can rotate freely.

6.2 Transmission

6.2.1 Daily Maintenance of V Belts

Transmission belts are fixed according to motor power.

1) Check the V belts

Check V belts' tensility after a full-load operation for 20-30 hours. And then check its abrasion condition monthly.

2) Check V belts' tensility every 6 months.

Remove the upper panel in the back end of the granulator.

Rotate the V belts for several circles to see if there is any damage.



CAUTION!

Pinch risk! Do not place your hands between wheels and the belts.

If it is necessary, check the belt's tensility via enforce extra force (150N) and measure its excursion. (This excursion is determined by central distance L of the belt pulley).

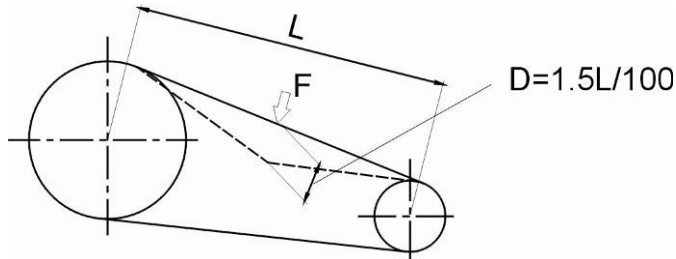

Picture 6-4: Transmission

6.2.2 Adjustments of V Belts

- 1) Take down the side plate on the control box that is located on the right side of the machine.
- 2) Take out the storage box; loose the position adjusting screws of the motor.



Picture 6-5: Adjustments of V Belts 1

- 3) The tension of the belt could be altered by adjusting the distance between motor and driving wheel. Tighten the screws after you finished the adjustment.



Picture 6-6: Adjustments of V Belts 2

- 4) Recheck the belts' tensility after a full-load operation for 20-30 hours.

6.3 Maintenance

When carrying out maintenance, ensure that there is no material left in the granulator.



CAUTION!

All stuff concerning repair must be conducted by professionals to avoid damage or harm to human body.

6.3.1 Daily check

- 1) There is rubber shutter in the feed box. If the rubber shutter is damaged, replace it immediately. Otherwise the fragment of the shutter will damage the blades in the cutting chamber and besides that, it will cause personal injury as it makes the grinded material shoot out during granulating.
- 2) Check whether the emergency stop works properly. Start the machine and then stop it via emergency stop. Rotate the button anti-clockwise to reset the emergency stop.
- 3) Check main power if Switches work normally.
- 4) Check star screw, safety screw is part of granulator' safety system, its length is pre-designed, when the screw is loosen, the granulator will stop working so to protect the machine. The thread length of the safety screw is 60 mm, damaged screw needs to be replaced by a new one.

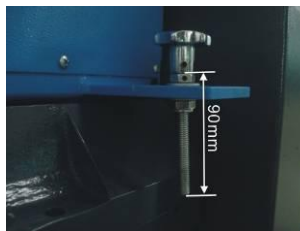

Picture 6-7: Star Screw

6.3.2 Weekly Check

- 1) Check the power wire to see whether there is any damage. If so, replace it immediately.
- 2) Check the safety switch.

6.3.3 Monthly Check

- 1) Check the motor operation.
- 2) Check the belt's tensility every 6 months. More details to see chapter 6.2 Transmission.

6.4 Cleaning



Caution:

Cutting blades are very sharp, extreme caution must be used when working on an open cutting chamber.

- 1) Check the cutting chamber is clear before stopping the granulator.
- 2) Switch of the main power
- 3) Cleanning plate of the feed box with dust-collecting machine.
- 4) Cleaning external surface of the feed box.
- 5) Open the feed box.
- 6) Clean all internal surfaces of the feed box.
- 6) Remove and clean the material collection box.
- 8) Clean screen and screen bracket.
- 9) Outer and inner of cutting chamber.
- 10) Cleaning belt pulleys with shinning dust-removing agent.
- 11) Blow the Clearance hole in the side plate of cutting chamber with pressed air (A), and rotate blades to remove cutting material inside bearing block.
Suggest Cleaning once a day.

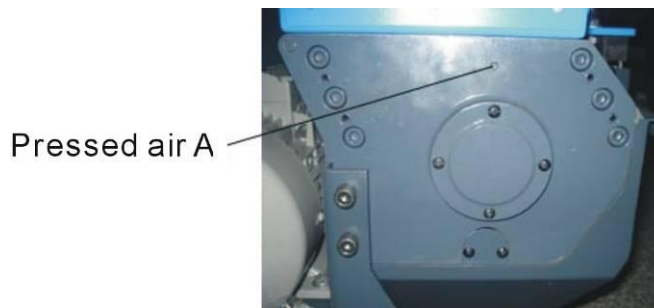

Picture 6-8: Clearing the Dust Collection Chambers



Caution!

Cover safety switch with a protective sleeve to avoid any dusts.

6.5 Maintenance Schedule

6.5.1 About the Machine

Model _____ SN _____ Manufacture date _____

Voltage _____ Φ _____ V Frequency _____ Hz Power _____ kW

6.5.2 Check After Installation

- Check if pipe connections are firmly locked by clips.
- Check the gap between fixed blade and rotating blade. (0.2mm).
- Check the rotating balance of the belt wheel.

Electrical Installation

- Voltage: _____ V _____ Hz
- Specs of the fuse: 1 Phase _____ A 3 Phase _____ A
- Check phase sequence of the power supply.
- Check the rotating direction of the conveying blower.

6.5.3 Daily Check

- Check main power switch.
- Check emergency stop button.
- Check start / stop button.
- Check material check plate (strip) is perfect or not.
- Check whether emergency stop and safety switch works normally.
- Clean screen and feeding hopper.
- Check whether start, stop and power switches are normal.

6.5.4 Weekly Check

- Check all the electrical cables.
- Check if there are loose connections of electrical components.
- Check blade condition.
- Check whether set screws in fixed and rotate blades are under looseness.
- Check if there is abnormal noise, vibration and heat in reduction gear.

- Check the cracking window

6.5.5 Monthly Check

- Check the status of the belt.
- Check the overload protection function of the motor.
- Check motor reversed running function.
- Check the tightness of the blades.
- Check whether clamp ring of pulley is fastened.
- Check belt tension.

6.5.6 Check Half-yearly or Every 1000 Running Hours

- Check or replace lubrication for gear motor.
- Check lubrication of bearing.
- Check coupling.
- Evaluation of the machine condition.

6.5.7 3 year Checking

- PC board renewal.
- No fuse breaker renewal.